

DISTRIBUTION SOLUTIONS

UniGear ZS3.2

Medium-voltage air-insulated switchgear up to 40.5 kV



- Standard design
- Safety upgrade
- Performance improvement
- Smart switchgear

Table of contents

1. Summary	05
2. Technical data	06
3. Switchgear panel structure	08
4. Main apparatus on the main circuit	16
5. Main components in the auxiliary circuit	20
6. Main wiring diagrams	21
7. Switchgear arrangement at site	25
8. Ordering instruction	27

UniGear ZS3.2

Product features

Standard design

Based on the innovative SmarTube technology, full range of air clearance above 300 mm in a panel width of 1400 mm

Safety upgrade

Anti-dumping mechanism of circuit breaker truck protects the personal safety during operation and maintenance, and the motorized circuit breaker truck and earthing switch help the new energy power plant completely realize the unattended substation.

Performance improvement

Whole panel has passed the level 2 ageing test, which belongs to Class 2 of enclosed switchgear for use in special service conditions with respect to condensation and pollution. The partial discharge level is very low. ET1 earthing switch has the withstand short-circuit making operation up to 5 times, and the required operating torque is highly reduced.

Smart switchgear

The innovative SmarTube third-generation IoT technology, the combination of embedded sensor technology and powerful edge computing capability realize comprehensive intelligent sensing of switchgear temperature rise, motion, position and environment. The temperature rise algorithm based on artificial intelligence can personalize the learning of the temperature rise characteristics of the switchgear after it is put into operation, automatically adapt to various panel variants and widths, changes in the operation mode of adjacent panels and environmental fluctuations around the switchgear, and fit an accurate temperature rise prediction model in a data-driven manner. Artificial intelligence technology helps users to more accurately grasp the operating status of the switchgear, reduce operating costs, make better decisions, and improve power supply reliability and continuity

1 Summary

1.1 General

UniGear ZS3.2 is three-phase, metal-enclosed, air-insulated, LSC-2B switchgear and all the panels are factory-assembled, type-tested and suitable for indoor applications up to 40.5 kV. The panels are designed as withdrawable modules and are fitted with a single busbar system. The withdrawable parts are equipped with circuit-breakers.

Details of the technical design and configuration of individual switchgears can be found in the relevant order documents, such as the technical data, detailed equipment lists for the individual panels, comprehensive circuit documentation and etc.

1.2 Standards and specifications

UniGear ZS3.2 comply with the standards and specifications for factory assembled, metal-enclosed and type tested high voltage switchgear to IEC publications 62271-200, 62271-1 and GB/T 3906. In addition, in accordance with IEC 60529, the switchgear panels have the following degrees of protection:

- IP 4X for the enclosure and IP 2X for the partitions.
- All other corresponding IEC publications, national or local safety at work regulations and safety regulations for production materials must be followed during erection and operation of these systems. Above and beyond this, the order-related data from ABB must be taken into account. Above and beyond this, the order-related data from ABB Xiamen Switchgear Co., Ltd. are to be taken into account.



1.3 Operating conditions

1.3.1 Normal operating conditions

The panels are fundamentally designed for the normal service conditions for indoor switchgears IEC publication 62271-200. The following limit values, among others, apply:

- Ambient temperature:
 - s Maximum +40°C
 - s Minimum -15°C
- Humidity
 - s -Maximum 24 h average of relative humidity 95%
 - s Maximum 24 h average of water vapour pressure 2.2 kPa
 - s Maximum monthly average of relative Humidity 90%
 - s Maximum monthly average of water vapour pressure 1.8 kPa
- The normal operational altitude is up to 1000 m above sea level.

The indoor ambient conditions are free of significant pollution, such as dust, smoke, corrosive and/or flammable gases, vapors or salt, etc.

1.3.2 Special service conditions

According to IEC 62271-1 and 62271-200, the manufacturer and user may agree on special service conditions which deviate from the normal service conditions. The manufacturer must be consulted in advance about each special service conditions. Examples are as follows:

- At site altitudes above 1000 m, the effects of the reduction in dielectric strength of the air on the insulation level are to be taken into account.
- Increased ambient temperatures must be compensated for in the design of the busbars and tee-off bars, or the current carrying capacity will be limited. Heat dissipation in the switchgear panel can be assisted by fitting additional ventilation facilities.

2 Technical data

2.1 Electrical data

Table 2/1 Main parameters

Main parameters	Unit	IEC/GB Value
Rated voltage ¹⁾	kV	36/40.5
Rated power frequency withstand voltage/1 min	kV	70/95
Rated lightning impulse withstand voltage	kV	170/185
Rated frequency	Hz	50, 60
Rated current of busbars ²⁾	A	1250, 1600, 2000, 2500, 3150
Rated current of tee-off bars ²⁾	A	1250, 1600, 2000, 2500, 3150
Rated current of circuit-breaker ²⁾	A	1250, 1600, 2000, 2500, 3150
Rated peak withstand current	kA	63,80
Rated short-time current(4s) ³⁾	kA	25,31.5
Rated current of making and breaking	kA	25,31.5
Auxiliary voltage ⁴⁾	V	DC 110, 220; AC 110, 220

Note:

1) Up to 48 kV for certain region with selected variants.

2) Forced air cooling is used when the rated current is 3150 A.

3) Take the short-circuit withstand capability of the instrument transformers into account separately.

4) Special DC voltages on request.

2.2 Resistance to internal arc faults

The switchgear units have been tested in according with IEC 62271-200 standard (Annex A, accessibility type A, IAC classification FLR , criteria 1 to 5).

The internal arc fault withstand capacity is as follows: 31.5 kA/1 s.

2.3 Dimensions and weights

Table 2/2 Dimensions of UniGear ZS3.2 panels

Dimensions of UniGear ZS3.2 panels		
Height A/ mm	Width B/ mm	Depth C ¹⁾ /mm
2600	1400	2865/3165

Note:

1) Depth C value is 2800/3100 mm when it does not include the doors.

Dimension according to Figure 2/1.

Weight:1100 kg to 2000 kg, according to the equipment installed.

ABB wishes to highlight that values of dimensions and weights provided herein are preliminary and may change after final design preparation, based on final scope of supply and installation details of the switchgear. As a consequence, provided values of dimensions and weights are NOT to be considered as final but only for standard reference purposes.

Accordingly, you expressly acknowledge and agree that values of dimensions and weights provided herein are neither final nor binding and that the result of their use is neither feasible nor accurate nor error free.

—
Figure 2/1 Dimensions of
UniGear Z53.2 panels

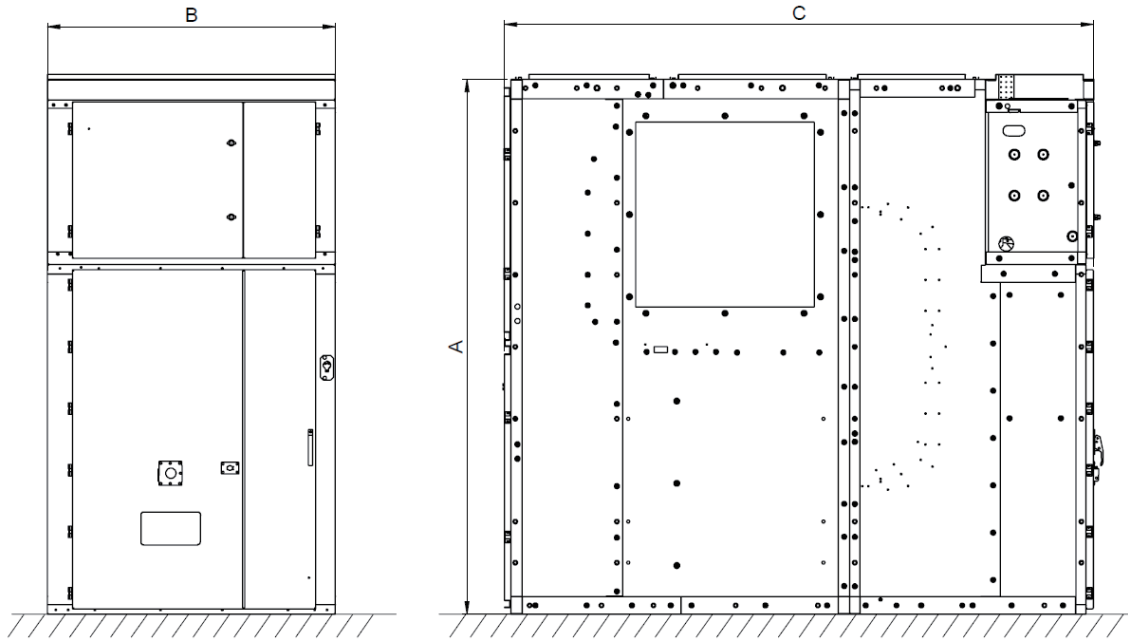

—
Figure 2/1

3 Switchgear panel structure and equipment installed

3.1 Compartments in the panels

The basic structure of the switchgear panels comprises the panel, which is fixed in position, and the movable, withdrawable part with vacuum circuit-breaker.

Figure 3/1 show the structure of panels and the electrical components installed.

The panel consists of the following compartments:

- Circuit-breaker compartment (CB comp.)
- Busbar compartment (BB comp.)
- Cable connection compartment (CA comp.)
- Low voltage compartment (LV comp.)

In addition to the feeder/incoming panel, UniGear ZS3.2 also has various panel types, such as: metering panel, bus riser panel , bustie panel etc.

Further details on the structure and equipment configuration of the switchgears can be taken from the order documents for the particular case.

3.2 Enclosure and partitions

The enclosure and internal partitions of the switchgear panels consist of high quality aluminium zink coated sheet steel, which is 2 mm thickness with excellent oxidation resistance and corrosion resistance. Three high-voltage compartments are fitted with secured pressure relief plates located at the top (NO. 1.1,1.2,1.3 in Figure 3/1). They will open upward if internal arc faults result in overpressure.

The doors of the switchgear panels and the cover plates of the end panels are thoroughly cleaned, treated to prevent corrosion, and then painted with a high-quality paint in colour RAL7035 (or special colours as agreed) which have excellent oxidation resistance and corrosion resistance.

Measures to mitigate the effects of arc faults are as following:

- Special rubber sealing rings are used between the switchgear and the doors.
- When the switchgears are spliced together, 4 mm air layer is formed between the side panels.
- Low voltage compartment is a unit completely separated from the high-voltage compartment of the switchgear, which has the performance of shock-proof and fire-proof.

The metal shutter (NO.10.1,10.2 in Figure 3/1) will automatically drop to the closed position when CB truck (NO.11 in Figure 3/1) is removed. The spout and the fixed contact (NO.4,4.1 in Figure 3/1) are completely shielded to ensure electrical insulation and avoid contact with high-voltage by personnel to truly achieve the PM level between compartments.

Pressure relief plates are composed of steel plate, grid plate or wave plate according to the current of tee-off bar. One side of the pressure relief plate is bolted with steel screws and the other side with plastic screws. When the pressure is so high in panel, the plastic screws break and the pressure relief plate will open. Cable clamp mounting plate (NO.15 in Figure 3/1) made of metal plates that are not magnetically conductive.

The influence of internal arc fault is related to the height of ceiling. In individual cases, additional protective measures are required. These measures are as following:

- (1) Top channel (NO.30 in Figure 5/4) lead the impact and arc particles from internal arc fault to the outside.
- (2) Low voltage compartment separates with high voltage compartment by metal sheet.
- (3) End cover (NO.29 in Figure 5/3) installs in end panel, which not only can ensure beautiful surface, but also can provide mechanical and thermal protection against internal arc fault.

Figure 3/1/1 UniGear ZS3.2 section view, basic structure of incoming/feeder panel

3.3 Compartments in the switchgear panels

3.3.1 Circuit-breaker compartment

Circuit-breaker compartment contains all the necessary equipment for reciprocal operation of the withdrawable part and the panel. It is metallically partitioned on all sides. (Detail in Figure 3/5)

The circuit-breaker compartment is fitted with the necessary guide rails accommodates the withdrawable part, which can be moved between the service position and the test/disconnected position. The fixed contacts in spout are located in mounting plate. The metal shutter plates which covers the spouts are also included.

When circuit-breaker moves to the test/disconnected position from service position, the shutter (NO.10 in Figure 3/1) will automatically close by chain drive, covering the fixed contacts in spout. The doors of panel can only be opened when the circuit-breaker is in the test/disconnected position to ensure the personal safety in the event of internal arc fault occurred during the rolling in and out of the truck.

The ON / OFF pushbutton located on the circuit-breaker and the mechanical indicators for ON/OFF and CHARGED / DISCHARGED can be observed through an inspection window (NO.23.3 in Figure 3/3).

The closing and opening operation of the circuit breaker can be carried out with the CB door closed, including the manual operation when the circuit-breaker truck is in the service position.

The socket for the control wiring (NO.24.4 in Figure 3/5) is mounted in the circuit-breaker compartment.

3.3.2 Busbar compartment

Main busbar and tee-off bar (NO.3,2 in Figure 3/1) use different type copper tube according to the rated current.

The main busbar and tee-off bar are sprayed with black paint, which has a good protection effect on the surface and conducive to heat dissipation. The shield electrode (NO.28 in Figure 5/6) with uniform electric field are installed at its connection position, which is conducive to improving the insulation performance. Because of the bushing and plates, panel by panel partitioning is realised.

3.3.3 Cable connection compartment

Current transformers, arresters, earthing switch (with manual operating mechanisms), voltage transformers (NO.8,17,7,31 in Figure 3/1), and so on are located in cable compartment, it also can connect multiple parallel cables. The arresters are fixed and connected to the primary circuit with bolts, the bolts are covered with shield (NO.14.1 in Figure 5/8).

3.3.4 Low voltage compartment

(Figure 3/9)

Low voltage compartment and it's door can be installed with various secondary equipment according to different requirements.

There are secondary wiring trough made of metal plates in LV compartment with sufficient space. Secondary wiring inside the panel is on both side of the panel which enter LV compartment from wiring trough.

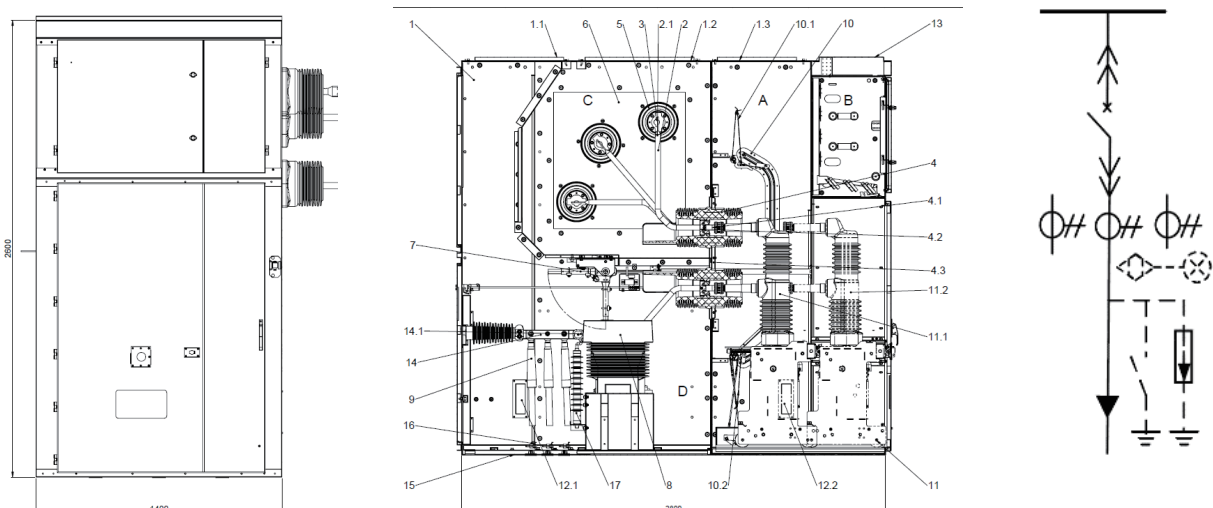

Figure 3/1/1

Figure 3/1/2 UniGear ZS3.2 section view, basic structure of PT panel

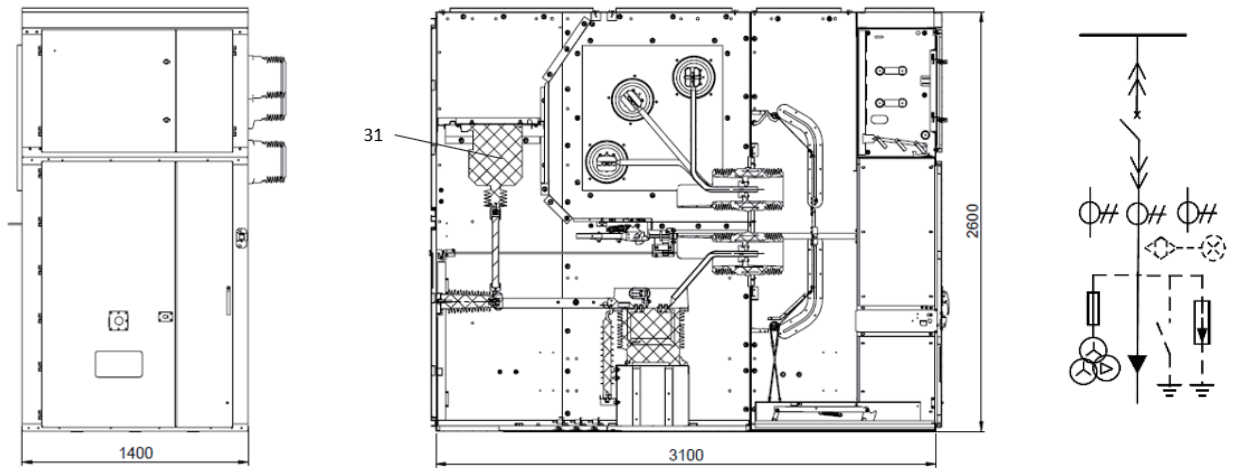

Figure 3/1/2

- | | | | |
|-----|---------------------------------------|------|--|
| A | Circuit-breaker compartment | 8 | Current transformer |
| B | Low voltage compartment | 9 | Cable |
| C | Busbar compartment | 10 | Shutter |
| D | Cable connection compartment | 10.1 | Upper shutter |
| 1 | Panel | 10.2 | Lower shutter |
| 1.1 | Pressure relief plate in CA comp. | 11 | Circuit-breaker truck |
| 1.2 | Pressure relief plate in BB comp. | 11.1 | Service position of CB truck |
| 1.3 | Pressure relief plate in CB comp. | 11.2 | Test position of CB truck |
| 2 | Tee-off bar | 12 | Heater |
| 2.1 | Temperature sensor in tee-off bar * | 12.1 | Heater in CA comp. |
| 3 | Main busbar | 12.2 | Heater in CB comp. |
| 4 | Spout | 13 | Small busbar compartment |
| 4.1 | Fixed contact | 14 | Cable connection bar |
| 4.2 | Temperature sensor in fixed contact * | 14.1 | Temperature sensor in cable connection bar * |
| 4.3 | Mounting plate for spout | 15 | Bottom plate |
| 5 | Bushing | 16 | Cable clamp |
| 6 | Mounting plate for bushing | 17 | Arrester |
| 7 | Earthing switch | 31 | Voltage transformer |

Note:

* mark: ABB Smart solution on request.

—
Figure 3/2 circuit-breaker

3.4 Circuit-breaker (Figure 3/2)

The circuit-breaker is withdrawable version which consists of a frame made of high-strength sheet steel and poles mounted on the frame and operating mechanism and auxiliary components are installed.

Contact arms with spring-loaded contact systems (NO.57.1,57.2,57.3 in Figure 3/2) are fitted to the circuit-breaker poles. They create the electrical connection to the switchgear panel when the withdrawable part is inserted into the service position. Detail information on the vacuum circuit-breaker can be found in the corresponding instruction manual.

The signalling, protection and control wiring between the switchgear panel and the withdrawable part is coupled by a multiple pin control wiring plug connector (NO.24 in Figure 3/4).

As soon as withdrawable part has been slid into the switchgear panel and its interlock yoke of handcar fixed link (NO.51 in Figure 3/2) has engaged in the test/disconnected position, it is positively connected to the switchgear panel. At the same time, it is earthed by earthing contact (NO.50.1 in Figure 3/2). The position of the withdrawable part can be checked on the electrical position indicator or through the sight glass (NO.23.3 in Figure 3/3) in the door at any time. The energy spring mechanism and controls and indicators of the circuit-breaker, the operator can easily operate or observe the above components when the CB door is closed.

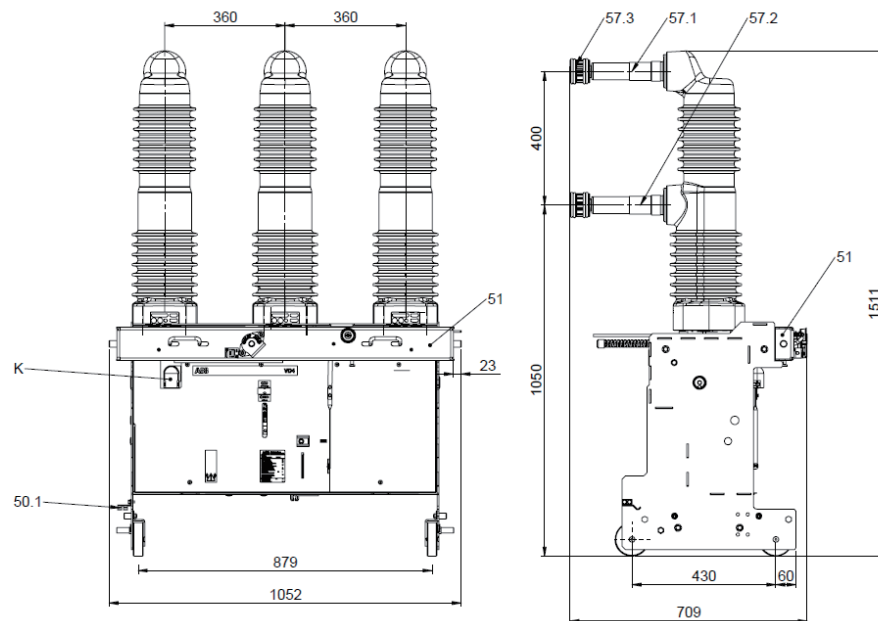

—
Figure 3/2

- 51 Circuit breaker fixed link
- 50.1 Earthing contact
- 57.1 Upper contact arm
- 57.2 Lower contact arm
- 57.3 Spring-loaded contact system

3.5 Interlock/protection against incorrect operation

A series of interlocks are provided to prevent fundamentally hazardous situations and maloperation, thus protecting both personnel and the switchgear. The interlocks which are normally individually effective are as follows.

3.5.1 Panel internal interlocking

- (1) The withdrawable part can only be moved from the test / disconnected position (and back) when the circuit-breaker and earthing switch are off (i.e. the switch must be off before hand.) In the intermediate position, the switch is mechanically interlocked. When the circuit-breaker has an electrical release, the interlock is also electrical.
- (2) The circuit-breaker can only be switched on when the withdrawable part is in the test or service position. In the intermediate position the switch is mechanically interlocked. When the circuit-breakers have an electrical release, the interlock is also electrical.
- (3) In the service or test positions, the circuit breaker can only be switched off manually when no control voltage is applied and it cannot be closed (electromechanical interlock).
- (4) The earthing switch can only be switched on if the withdrawable part is in the test / disconnected position or outside of the panel (mechanical interlock)¹⁾.
- (5) If the earthing switch is on, the withdrawable part cannot be moved from the test / disconnected position to the service position (mechanical interlock).
- (6) When the withdrawable part is in the service position, the CB door cannot be opened to ensure that control wiring plug cannot be operated.
- (7) Optionally there can be interlocking on shutters to prevent manual opening. If it is applied then a shutter device must be specified.

3.5.2 Door interlocking

- (1) The circuit-breaker cannot be racked-in if the circuit-breaker compartment door is open.³⁾ (Figure 3/10)
- (2) The circuit-breaker compartment door cannot be opened if the circuit-breaker is in service or in an undefined position. (Figure 3/11)
- (3) The rear door of the cable compartment cannot be opened if the earthing switch is open. (Figure 3/12)
- (4) The bolts on the circuit-breaker compartment door and cable connection compartment door can be loosened to realize emergency unlocking. (Figure 3/13)

3.5.3 Interlocks between panels

- (1) The earthing switch which is for main busbar earthing can only be closed when all the withdrawable parts in the relative busbar section are in the test /disconnected position (electromechanical interlock)²⁾.
- (2) When the earthing switch which is for main busbar earthing is closed, the withdrawable parts in the earthed busbar section cannot be moved from the test /disconnected position to the service position (electromechanical interlock)²⁾.

3.5.4 Locking devices

- (1) The shutter can be secured independently of each other with padlocks (NO.10.3 in Figure 3/5) when the withdrawable part has been removed.
- (2) Access to the operating-shaft of the earthing switch can be restricted with a padlock (NO.22 in Figure 3/3).
- (3) Access to the circuit-breaker racking slot can be restricted with a padlock (NO.23.2 in Figure 3/3).
- (4) Access to the doors be restricted with a padlock.

Note:

- 1) The locking magnet is not installed in the case of a motor operator. Earthing switch or the withdrawable part are electrically locked. The manual emergency switch is not locked!
- 2) Because the interlock is a mechanical interlock, the motor operator truck does not have the function.
- 3) The apparatus compartment door interlock is not available for motor operated withdrawable apparatus as a mechanical device. Manual operation of a motorized withdrawable part should be performed in emergency case only!

Figure 3/3 Front view of switchgear panel

Figure 3/4 Circuit-breaker in remove position

Figure 3/5 Circuit-breaker compartment

Figure 3/6 Fixed contact system

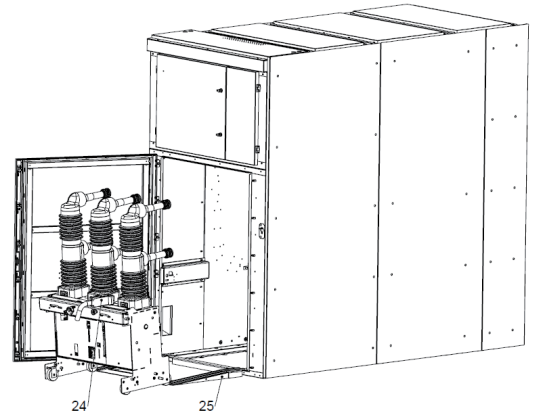

Figure 3/3

Figure 3/4

- 21 Low voltage compartment
- 22 Handle hole of earthing switch
- 23 CB comp. door
- 23.1 ON / OFF handle hole of circuit-breaker
- 23.2 Handle hole of circuit-breaker
- 23.3 Observation window
- 24 Multi-pin aviation socket
- 25 Guide rail of truck

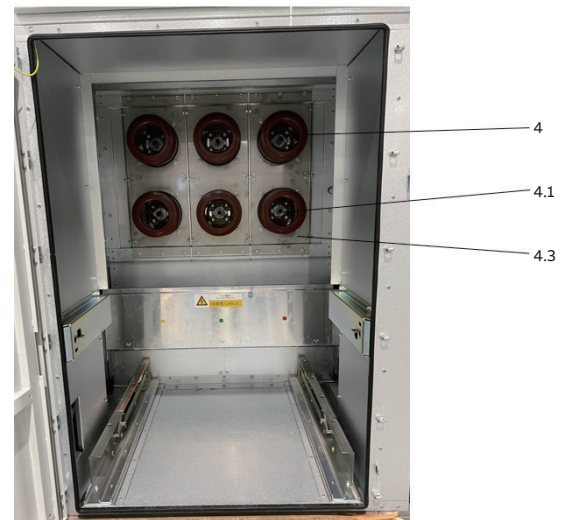
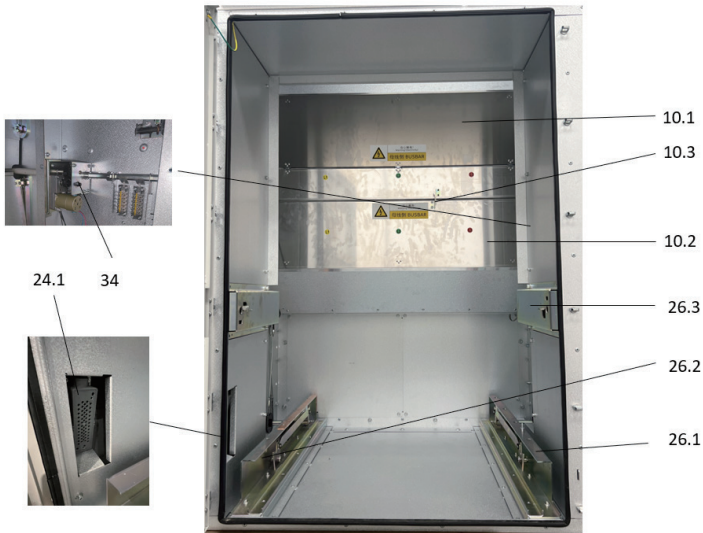

Figure 3/5

Figure 3/6

- 10.3 Padlock position of shutter
- 24.1 Socket
- 26.1 Right guide rail of circuit-breaker
- 26.2 Left guide rail of circuit-breaker
- 26.3 Truck lock device
- 34 Electric earthing switch driving device

- Figure 3/7 Cable connection compartment
- Figure 3/8 Main busbar compartment
- Figure 3/9 Low voltage compartment
- Figure 3/10/1 Circuit-breaker truck enabling slot
- Figure 3/10/2 CB comp. door enabling device



- 27
- 7
- 8
- 14
- 16

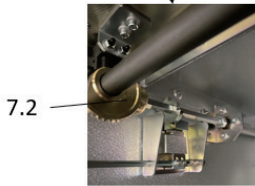

- 7.1

- 7 Earthing switch
- 7.1 Gear-driven
- 7.2 Fixed contact of earthing switch
- 27 Main Earthing circuit

Figure 3/7

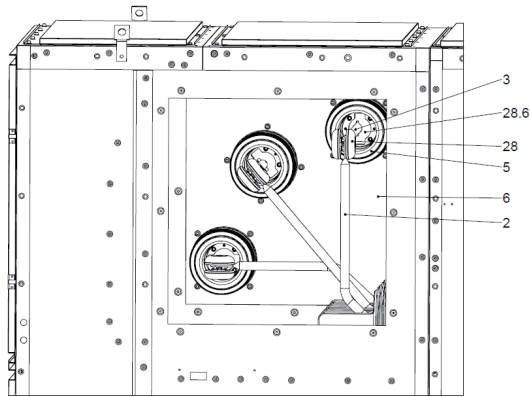

Figure 3/8

- 28 Shield electrode
- 28.6 Dust spacer

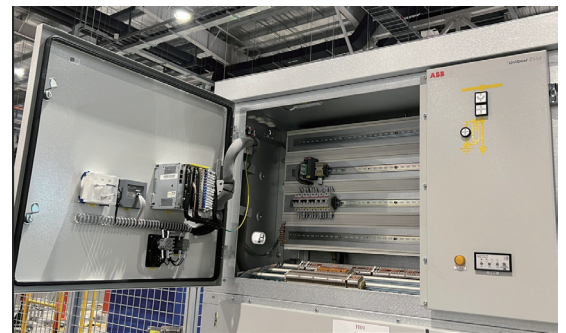

Figure 3/9



Figure 3/10/1

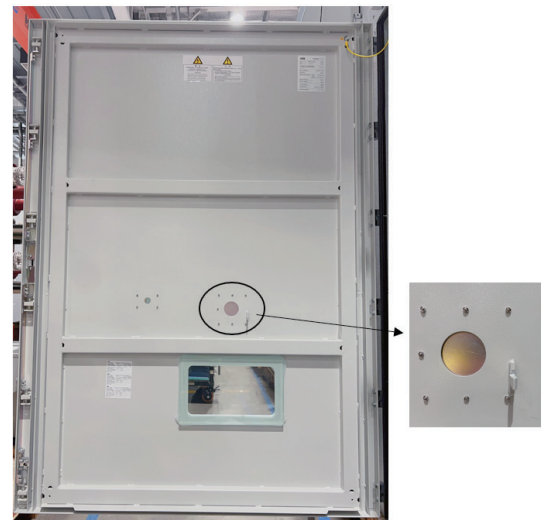

Figure 3/10/2

Figure 3/11/1 CB comp. door locking device

Figure 3/11/2 CB comp. door limit device

Figure 3/12/1 CA comp. door enabling device

Figure 3/12/2 CA comp. door emergency enabling device

Figure 3/13/1 CB comp. door emergency enabling device

Figure 3-13/2 CA comp. door emergency enabling device



Figure 3/11/1



Figure 3/11/2



Figure 3/12/1

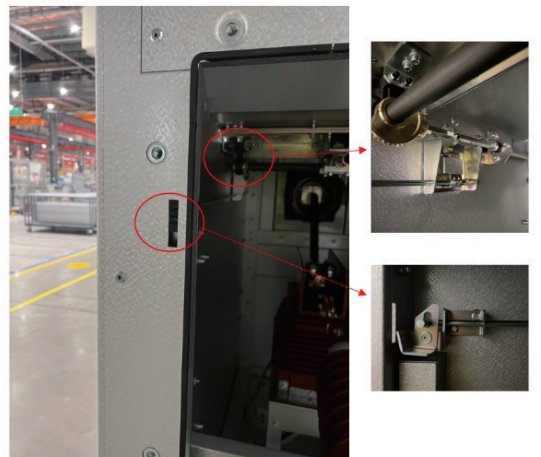

Figure 3/12/2



Figure 3/13/1



Figure 3/13/2

4 Main apparatus on the main circuit

—
Figure 4/1 40.5 kV VD4
side view

—
Figure 4/2 40.5 kV VD4
side view

All apparatus in the main circuit are developed by ABB group, or provided by ABB qualified suppliers. This ensures that each UniGear ZS3.2 has the same quality, stable performance, safety and reliability.

Below is the simple instruction of the main apparatus in the main circuit. As for detail message and parameters of these apparatus, please see related product specifications (VD4: 1YHA000093).

4.1 Circuit-breaker

The VD4 vacuum circuit-breaker is one of the main apparatus in the main circuit (Figure 4/1, Figure 4/2). It is produced by ABB, and applies to IEC standards and Chinese GB/T.

Vacuum circuit-breakers have particular advantages for use in networks where there is a high switching frequency in the working current range and/or where a certain number of short-circuit breaking operations are expected.

Type VD4 vacuum circuit-breakers are suitable for auto-reclosing, and have exceptionally high operating reliability and long life.

The operating mechanism is fundamentally suitable for auto-reclosing and, due to the short charging times, also for multi-shot auto-reclosing.

Technical parameters of VD4 as below Table 4/1, 4/2 and Figure 4/5

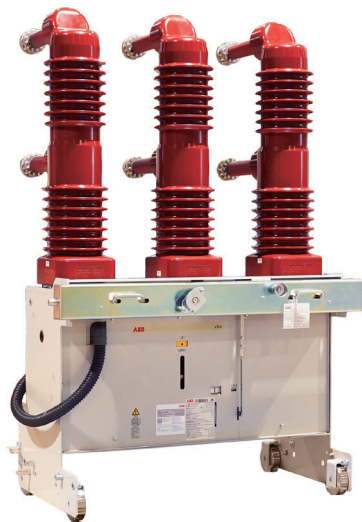

—
Figure 4/1

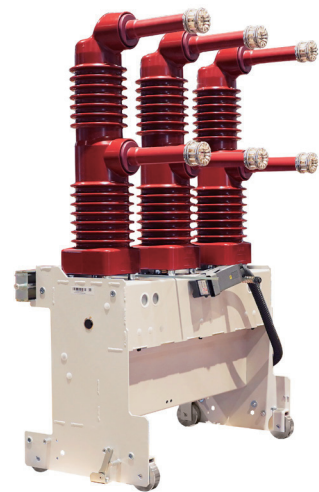

—
Figure 4/2

Table 4/1 Technical parameters of the VD4 vacuum circuit-breaker

Item	Unit	IEC					GB/T
Rated voltage	kV	36					40.5
Rated power frequency withstand voltage/1 min	kV	70					95
Rated lightning impulse withstand voltage	kV	170					185
Rated frequency	Hz	50					
Rated current	A	1250	1600	2000	2500	3150*	
Rated peak withstand current	kA	...63, 80					
Rated short-circuit breaking current	kA	...25, 31.5					
Rated short-time withstand current 4 s	kA	...31.5					
Rated operating sequence		O-3 min-CO-3 min-CO					
Rated operating sequence with auto-reclosing		O-0.3 s-CO-3 min-CO					
Closing time	ms	55-67					
Opening time	ms	30-45					
Arcing time (at 50 Hz)	ms	≤15					
Net weight	Kg	240	270	270	320	320	

* Forced ventilation

Table 4/2 VD4 operation mechanism parameter

	Auxiliary	Motor consumption	Charging time (s)	Closing trip power	Opening trip power	Locking electromagnet
	(V)	Power (VA/W)	(Max)	(VA/W)	(VA/W)	Power (VA/W)
AC	110	350	15	250	250	10
	220	350	15	250	250	10
	240	380	15	310	310	10
DC	24	330	15	250	250	10
	48	330	15	250	250	10
	60	330	15	250	250	10
	110	280	15	250	250	10
	220	280	15	250	250	10

4/5 Permissible number of VD4 vacuum interrupter switching operations in relation to breaking current

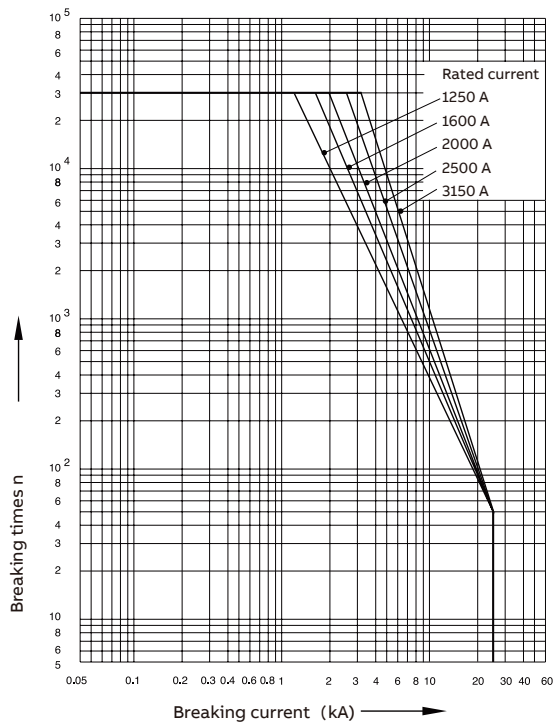

a) 40.5 kV, 1250...3150 A, 25 kA

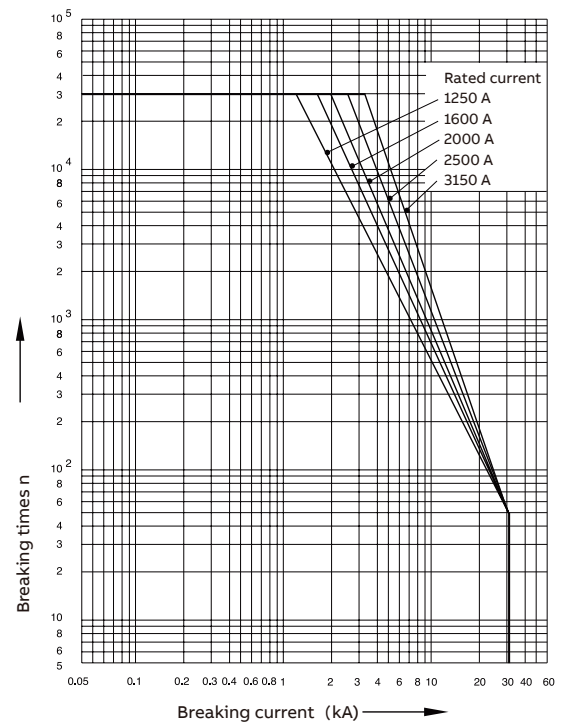

b) 40.5 kV, 1250...3150 A, 31.5 kA

—
4/7 MWD/MWK
surge arrester

—
4/8 Earthing switch

4.2 Surge arrester

The MWK/MWD is a surge arrester intended for use in high and medium voltage applications. Surge arresters protect the insulation of high voltage and medium voltage devices against over voltages which are caused by lightning or switching operations.

The MWK/MWD surge arrester is made of serially connected, non-linear metal-oxide (MO) resistors. These MO resistors have an extremely non-linear resistance property. At the maximum operating voltage of U_c , only a small capacitive current will flow in the mA range. With an increase in voltage, the MO resistors enter a highly-conductive state practically without delay. Thus any further increase in voltage is limited to the specified residual voltage values. After the decline of the over voltage the arrester immediately turns back to the non- or slightly-conductive state. The MO arrester converts the energy of the surge into heat, which it transfers to the surrounding air.

The stack of MO resistors and connection equipment is held together with strong strips made of fiberglass-reinforced plastic. The directly molded silicone housing with sheds protects it from all environmental and weather influences. This design has proven to be the best solution in every environment for years. For indoor applications without pollution sheds are not required.

Thanks to its high energy absorbing capability and low protective level, the MWK, MWD is especially suited for overvoltage protection of:

- Transformers
- Cables, motors
- Other high- and medium-voltage apparatuses and systems

4.3 Earthing Switch (Figure 4/8)

Earthing switches of series ET1 are determined for indoor installation and confirmed to the requirements of IEC publications of 62271-102 and Chinese GB/T 1985. They are fitted with snap-action operating mechanisms for positive high-speed closing and sufficiently dimensioned to conduct rated short-current making current when closed under load. The speed of the snap-action closing operation is independently controlled.

The earthing switches are supplied as kits with a pre-assembled active part and corresponding earthing contacts supplied loose. Correct installation of these parts in a switchgear panel results in a functioning earthing switch.

Routine tests to IEC 62271-102 and Chinese GB/T 1985 are to be carried out at the site accordingly.

—
Table 4/3 Technical parameters of the surge arrester

Type	Rated voltage (kV)	Continuous working voltage U_c (kV)	Residual voltage at different waves and discharging currents (kV)										
			1/3 μ s			8/20 μ s			30/60 μ s				
MWD /MWK			1 kV	5 kA	10 kA	1 kV	5 kA	10 kA	20 kA	100 A	250 A	500 kA	1000 kA
41	51.3	41	107.4	131.6	148.6	106.6	118.9	125.9	139.4	92.7	97.6	100.9	105.0
44	55.0	44	115.3	141.3	159.4	114.4	127.6	135.1	149.6	99.4	104.7	108.2	112.7



MWD

—
4/7



MWK

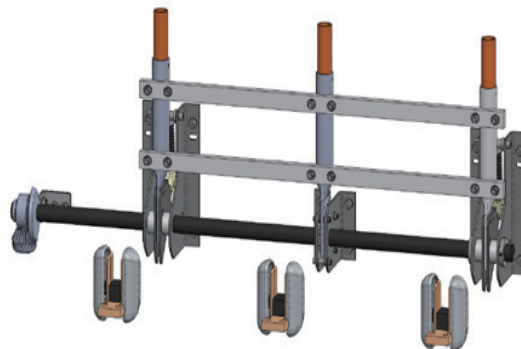

—
4/8

—
4/9 Current transformer
—
4/10 Voltage transformer

4.4 Transformer

UniGear ZS3.2 is fitted with current transformer and voltage current supplied by ABB qualified suppliers.

Ensure it has the same life with the switchgear. Its main parameters are shown in Table 4/7 and Table 4/8.

Attention: The short-time withstand current and the peak withstand current of the current transformer should be recertified according to the transformation ratio.

—
Table 4/6 ET1 parameters

Item	Unit	Parameters
Rated voltage	kV	40.5
Distance of ph-to-ph.	mm	360
Rated short-time withstand current	kA/s	31.5/4
Making current (peak)	kA	80
Operating voltage of electromagnet	V	DC48, 110, 220; AC110, 220

—
4/9



—
Table 4/7 Technical parameters of the current transformer

Item	Unit	Data
Rated voltage	kV	40.5
Rated frequency withstand voltage	kV	95
Rated lightning impulse withstand voltage (peak value)	kV	185
Rated primary current	A	50...3150
Rated secondary current	A	1, 5
Accuracy class		0.2, 0.5, 1.0, 3.0, 5P10, 5P20, 10P10, 10P20
Rated capacity	VA	10...30
Rated short-time withstand current (4 s)	kA	25, 31.5
Rated peak withstand current	kA	63, 80

—
Table 4/8 Technical parameters of the voltage transformer

Item	Unit	Data
Rated primary voltage	kV	35/ $\sqrt{3}$ 35
Rated frequency withstand voltage	kV	95
Rated lightning impulse withstand voltage (peak value)	kV	185
Rated secondary voltage	V	100/ $\sqrt{3}$ 100
Accuracy class		0.2, 0.5, 1.0, 3.0
Rated capacity	VA	20-100

—
4/10



5 Main apparatus in the secondary circuit

5.1 Protect Relay

In principle, UniGear ZS 3.2 is fitted with ABB group's advanced Relion series comprehensive protective relay, and also fitted with other relay according to the customer's requirements.

Relion® protection and control relays

The Relion® product family offers the widest range of products for the protection, control, measurement and supervision of power systems for IEC and ANSI applications – from generation and inter-connected grids over primary distribution to secondary distribution kiosks.

The ABB Relion protection relays are deeply rooted in ABB's vast experience of developing successful protection and control relays. These relays have been developed during many years and are built on the experience gathered from wide ranging application and functionality requirements of ABB's customers globally.

To ensure interoperable and future-proof solutions, Relion products have been designed to implement the core values of the IEC 61850 standard. The genuine implementation of the IEC 61850 substation modelling and communication standard covers both vertical and horizontal information exchange between protection relays and external systems. The protection and control IED manager PCM600 provides versatile functionality throughout the life cycle of all Relion protection and control relays. PCM600 is IEC 61850 compliant, which ensures smooth engineering of the relays and enables information exchange with other IEC 61850 compliant tools.

With these products, you benefit from ABB's leading-edge technology, global application knowledge and experienced support network. The Relion technology is leading the way and setting the future trends in the field of protection and control systems.

5.2 Measuring instrument

Measuring instruments are arranged, mainly according to the requirements of the user, and meet the requirements of GB/T measuring instrument guide. UniGear ZS3.2 is equipped with imported instruments, including the electric energy meter, counting meter and transmitter. It can also be based on the user's requirements with the specified domestic instrument.

5.3 Auxiliary switch

UniGear ZS3.2 is equipped with a variety of ABB auxiliary switches, which are reliable in quality.

5.4 Position indicator

The positions of the circuit breaker and the earthing switch are indicated by the LED position indicator which is combined with a simulate bus. It has the advantages of low power consumption, long life, distinct instructions and so on. It can also be used to monitor the operation of the power supply and monitor the truck is in place.

5.5 Other components

Operation power protection by ABB or the world well-known company Micro air circuit-breaker (MCB), in principle does not use low voltage fuses, to reduce wearing parts.

The auxiliary switch and the secondary connector are all ABB's patented products. Simple structure, excellent performance and reliable operation.

6 Main wiring diagram

Classification code of each function in main wiring diagram

I-Incoming, F-Feeder, D-Divider, B-Bus-tie, R-Bus-riser, M-Measuring, P-Voltage measuring, T-Transformer

Solution code	01	02	03	04	05
Main wiring diagram					
Rated current	1250-3150	1250, 1600	1250, 1600	1250	1250
Main device	Breaker VD4	1	1	1	1
	Current transformer	3	3	3	3
	Voltage transformer		3	3	
	Fuse		3		
	Earthing switch	Option		Option	
	Surge arrester	Option	Option	Option	Option
	Electrification indicator	Option	Option	Option	Option
Function	I.F	I.F	I.F	I.F	I.F

Solution code	06	07	08	09	10
Main wiring diagram					
Rated current	1250	1250, 2000	1250-3150	1250	1250-3150
Main device	Breaker VD4	1	1	1	1
	Current transformer	0-3	3	3	3
	Voltage transformer				
	Fuse				
	Earthing switch	Option			
	Surge arrester	Option	Option		
	Electrification indicator	Option	Option	Option	Option
Function	I.F	B	B	I.B	I

Classification code of each function in main wiring diagram

I-Incoming, F-Feeder, D-Divider, B-Bus-tie, R-Bus-riser, M-Measuring, P-Voltage measuring, T-Transformer

Solution code	11	12	13	14	15
Main wiring diagram					
Rated current	1250	1250	1250-3150	1250, 2000	
Main device	Breaker VD4	1			
	Current transformer	3	3	3	
	Voltage transformer		3	3	3
	Fuse		3	3	3
	Earthing switch	Option	Option	Option	
	Surge arrester	Option	Option	Option	
	Electrification indicator	Option	Option	Option	Option
Function	I.F	I.F	I.F	I.F	P

Solution code	16	17	18	19	20	
Main wiring diagram						
Rated current				1250-2500	1250-2000	
Main device	Breaker VD4					
	Current transformer				3	
	Voltage transformer	3	3	3	3	3
	Fuse	3	3	3	3	3
	Earthing switch	Option	Option	Option		
	Surge arrester	Option	Option	3	Option	3
	Electrification indicator	Option	Option	Option	Option	Option
Function	P+M	P+M	P+M	B.P+M	B.P+M	

Classification code of each function in main wiring diagram

I-Incoming, F-Feeder, D-Divider, B-Bus-tie, R-Bus-riser, M-Measuring, P-Voltage measuring, T-Transformer

Solution code	21	22	23	24	25
Main wiring diagram					
Rated current	1250, 1600	1250	1250, 1600		
Main device	Breaker VD4				
	Current transformer	3	3		
	Voltage transformer	3	3		3
	Fuse	3	3		3
	Earthing switch				Option
	Surge arrester	Option	Option	Option	3
	Electrification indicator	Option	Option	Option	Option
Function	B,P	B,P	P	P	P

Solution code	26	27	28	29	30
Main wiring diagram					
Rated current		630	630	630	1250
Main device	Breaker VD4				
	Current transformer		3		
	Voltage transformer	4			
	Fuse	3	3	3	3
	Earthing switch	Option	Option		
	Surge arrester	Option	Option	Option	Option
	Electrification indicator	Option	Option	Option	Option
Function	P	T	T	T	B
		on request	on request	on request	

Classification code of each function in main wiring diagram

I-Incoming, F-Feeder, D-Divider, B-Bus-tie, R-Bus-riser, M-Measuring, P-Voltage measuring, T-Transformer

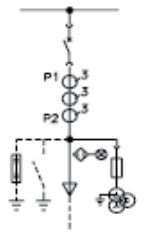
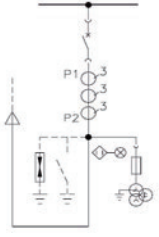
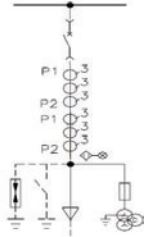
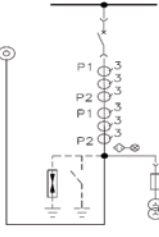
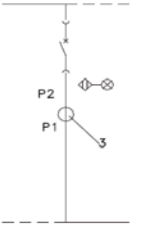
Solution code	31	32	33	34	35
Main wiring diagram					
Rated current	1250-2500	1250-2500	1250-2500	1250-2500	1250
Main device	Breaker VD4	1	1	1	1
	Current transformer	3	3	6	6
	Voltage transformer	3	3	3	3
	Fuse	3	3	3	3
	Earthing switch	Option	Option	Option	Option
	Surge arrester	Option	Option	Option	Option
Electrification indicator	Option	Option	Option	Option	Option
Function	I,F	I,F	I,F	T	B

7 Switchgear arrangement at site

To make sure a high quality of installation standard, site installation of the switchgear should only be guided and supervised by specially trained and skilled personnel.

7.1 General requirements of site installation

Switchgear site installation should be started after switch room is completely finished which it also includes lighting and site electricity supply. Switch room should be dry, lockable and include ventilation facility. All preparations should be done, like wall-through hole, cable trenches for powder and cable control, etc. The detail of switch room's roof height can be found in the installation manual of pressure relief duct.

In addition to special operation conditions of written approval, the switch room should meet the operation conditions of indoor switchgear specified in relevant standards and this user manual.

When installing pressure relief duct or top busbar duct on the top of switchgear, it should also meet the roof height.

Must ensure to meet the requirement of indoor switchgear working condition from IEC62272-1, include indoor temperature condition.

5.2 Foundation frame

(Figure 7/1)

The switchgear must be installed on foundation frame which is embedded in switch room's floor according to typical drawing of ABB Xiamen Switchgear Co. Ltd.

Relevant civil engineering regulations should be followed when laying the foundation, especially the requirements for straightness and flatness of foundation in this manual.

The foundation frame, consisting of one or more parts depending on the size of the switchgear. It is usually laid by on-site civil personnel. If possible, adjustments and inspections should be made under the supervision and guidance of ABB specialist.

Installation of the foundation frame:

- (1) In order to achieve the required surface levelness of the foundation frame, the welding components of the foundation frame should be welded at the predetermined connection points according to the prescribed procedure.
- (2) According to the installation drawing of the switch room, accurately place the foundation frame at the specified position on the concrete floor.
- (3) Carefully align the foundation frame along the entire surface and to the correct height with a levelling instrument. The upper surface of the foundation frame should be 5~12mm higher than the finished switch room floor for the installation, adjustment, and operation of the switchgear. Exceeding this range may pose certain risks. Please ensure that the height is within the allowable range:
 - e.g. flatness tolerance: $\pm 1\text{mm/m}$ within a measuring length of 1 m.
 - e.g. straightness tolerance: $\pm 1\text{mm/m}$ within a measuring length of 1 m, but not more than 5 mm over the entire length of the frame.
- (4) The foundation frame should have reliable earthing. The earthing should use a cross-section of not less than 30X4mm galvanized steel strip. When a group of switchgears are arranged, the foundation frame should be earthing at two ends.
- (5) After the completion of the supplementary layer of switch room floor, attention should be paid to backfilling the lower part of the foundation frame without leaving any gaps.
- (6) Foundation frame can't be subjected to any harmful impact and pressure, especially during the installation process.

Note:

The upper surface of the foundation frame should be 5~12 mm higher than the switch room.

Figure 7/1 Switchgear foundation

UniGear ZS3.2 Typical section arrangement of switch room

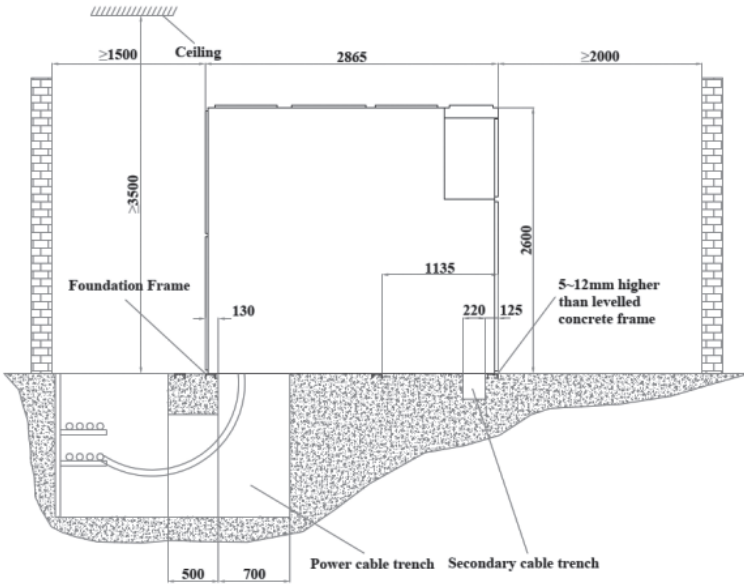

UniGear ZS3.2 Guideline structural data for foundation frame on concrete floor

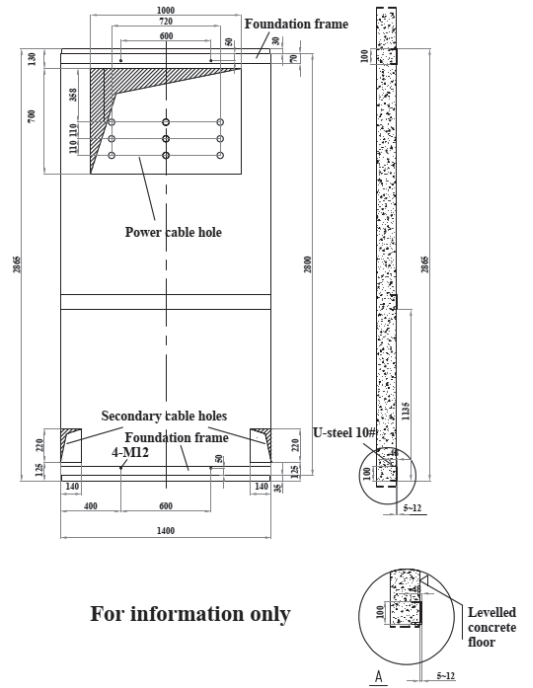

UniGear ZS3.2 Typical section arrangement of switch room

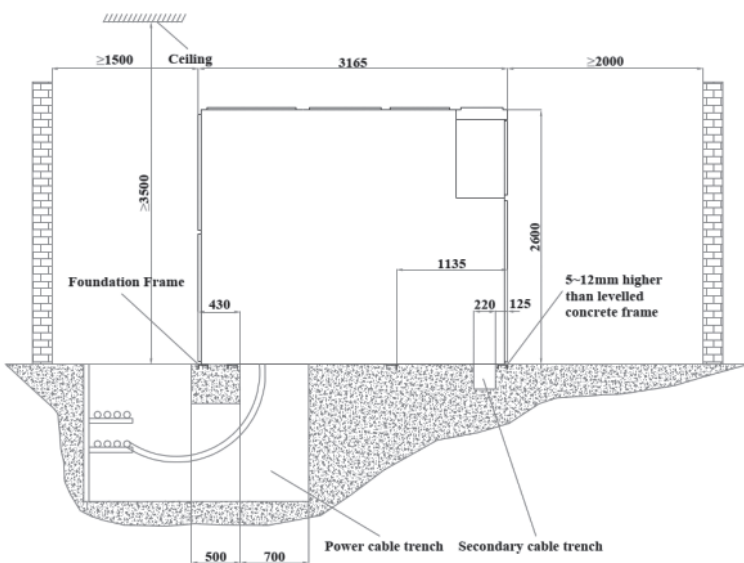

UniGear ZS3.2 Guideline structural data for foundation frame on concrete floor

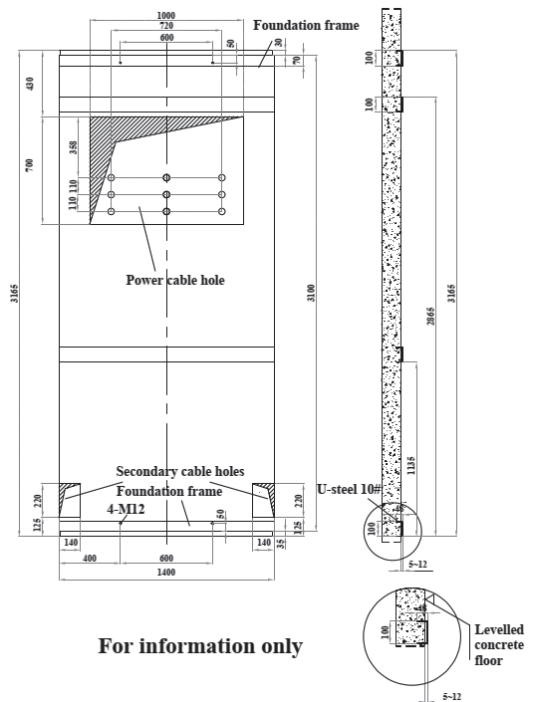

Figure 7/1

8 Ordering instruction

When UniGear ZS3.2 is booked, some issue should be made clear in the booking files as below:

- The main wiring scheme, the use and the single line system diagram, rated voltage, rated current, rated short-circuit breaking current, power distribution room layout plan and the arrangement of switch equipment, etc
- If a customer uses a power cable in and out of the cable, the power cable should be specified in the model and the number of roots
- Requirements for switching equipment control, measurement and protection functions, and other requirements for locking and automatic devices
- Model, specification and quantity of the main electrical components in the switchgear
- When switching equipment is used in special conditions, it should be explained in detail
- Other special requirements

