

TECHNICAL CATALOGUE

# UniGear ZS1

## Medium-voltage air-insulated switchgear

Comprehensive performance improvement



- Smaller
- Stronger
- Safer
- Smarter



---

# Contents

<b>1. Description</b>	04
<b>2. Product features</b>	05
<b>3. Customer benefit</b>	06
<b>4. Technical characteristics</b>	07
<b>5. Design features</b>	08
<b>6. Fully type-tested</b>	10
<b>7. Safety</b>	12
<b>8. Vaccum circuit-breaker</b>	16
<b>9. ConVac vacuum contactor</b>	18
<b>10. Service trucks</b>	21
<b>11. Instrument transformers</b>	23
<b>12. Cable terminations</b>	25
<b>13. Distribution automation</b>	27
<b>14. Single-line diagrams</b>	58
<b>15. Layout and Installation</b>	61
<b>16. UniGear Digital</b>	64

# Description

UniGear ZS1 adopts the advanced design concept. The performance is comprehensively improved and integration of IoT and digital technology make the operation of substation easier and safer.

The features are shown as follows.

**Smaller:** 500 mm panel width, most compact air-insulated switchgear with withdrawable VD4 circuit breaker.

**Stronger:** The circuit breakers with polyamide poles have excellent mechanical and electrical endurance capability. Meanwhile, the circuit breakers have high breaking capacity.

**Safer:** The innovative safety operation assistance system actively prevents electric shock accidents and ensures personal and equipment safety.

**Smarter:** The system provides comprehensive status awareness of switchgear through multidimensional real-time monitoring and analysis. It provides equipment asset health management and maintenance advice to ensure power supply safety, improve operation continuity and reliability, extend maintenance cycles and reduce maintenance costs, and make the change from preventive maintenance to predictive maintenance.

It has passed the compulsory test items stipulated by IEC Standard.

## Standards

The switchgear and main apparatus contained in it comply with the following Standards:

IEC 62271-1 for general purposes  
 IEC 62271-200 for the switchgear  
 IEC 62271-102 for the earthing switch  
 IEC 62271-100 for the circuit-breakers  
 IEC 60071-2 for the insulation coordination  
 IEC 62271-106 for the contactors  
 IEC 62271-103 for the switch-disconnectors  
 IEC 60529 for degree of protections

## Colour of the external surfaces

RAL7035 - light grey (front doors and side sheets). Other colours are available on request.

## Normal operation conditions

The rated characteristics of the switchgear are guaranteed under the following ambient conditions:

Minimum ambient temperature: – 5 °C

Maximum ambient temperature: + 40 °C

For different temperature ranges, please contact your ABB sales representative.

Ambient humidity:

Maximum 24 h average of relative humidity 95% RH

Maximum monthly average of relative humidity 90% RH

The normal operational altitude is up to 1 000 m above sea level. For higher altitude applications, please contact your ABB sales representative.

Presence of normal, non-corrosive and uncontaminated atmosphere.

## Degrees of protection

The degrees of protection of the switchgear conform with IEC 60529 Standards.

UniGear ZS1 switchgear is normally supplied with the following standard degrees of protection:

IP4X for the enclosure

IP2X for the partition between compartments

On request, the external housing can be supplied with a higher degree of protection; in this case please contact your ABB sales representative.

The electrical characteristics of the switchboard can vary for ambient conditions other than those described in the previous section and also if a higher degree of protection is used.

# Product features



## Insulating performance

UniGear ZS1 uses tubular branch copper bar to optimize the electric field strength of the main circuit. Compared to rectangular copper bar with the same current class, the air clearances between phases and phase to ground are increased. Combination with the optimized electric field design, the maximum electric field strength is significantly reduced. Without additional heat shrinkable sleeves and insulation covers, UniGear ZS1 still maintains sufficient insulation margins. Besides fully in compliance with IEC 62271-200, UniGear ZS1 also successfully passed the condensation test on UniGear ZS1 with the panel width of 500 mm.

## Partial discharge

The excellent electric-field distribution design keeps the partial discharge value in a low level, providing a reliable guarantee for the insulation performance of long-term operation.



## Temperature rise performance

The UniGear ZS1 uses ABB's advanced copper tube bending process to combine the tubular branch copper bar and static contacts into one unit, reducing 2 heating surfaces in the monoblock. Meanwhile, the tubular busbar has a larger heat dissipation area than the traditional flat busbar. These two points effectively improve the temperature rise performance.

## Internal arc

UniGear ZS1 passed internal arc test up to 40 kA/1 s/AFLR. The optimized less deeper door with the thickness of 40 mm provides more usable cabinet area.

## Earthing switch

The earthing switch type of UniGear ZS1 is ET1. ET1 adopts the tubular design as the same as the branch busbar. Compared with rectangular copper bars, ET1 is stronger in the electrodynamic direction, and its operation is excellent. Meanwhile, the capability to withstand short circuit making operation is up to 5 times. Mechanical operation life is up to 3,000 cycles (class M1).

ET1 is also available for motorized operation.

# Customer benefit

UniGear ZS1 is based on ABB's new generation of medium voltage switchgear technology platform. The performance is comprehensively improved and the IoT and digital technologies are highly integrated.

The application of tubular busbar technology has greatly optimized the distribution of the electric field in the switchgear. UniGear ZS1 passed the condensation test and the partial discharge reached low level. The innovative safety operation assistance system makes precise diagnosis and alarms against misoperation by maintenance personnel, effectively prevents electric shock accidents and actively protects for both switchgear and personnel.

The IoT solution with the embedded sensor technology and powerful edge computing capabilities enable comprehensive intellisense of temperature rise, motion, position and environment. It helps users to accurately understand the switchgear status, make better decisions, reduce operation and maintenance costs, and improve power supply reliability and continuity.

The compact design reduces the investment cost and makes efficient use of space. The tubular branch busbar effectively reduces energy consumption. Maximum utilization of environmental-friendly materials makes recycle available. UniGear ZS1 contributes to sustainability from multiple dimensions.

Compared with the traditional solution, the automatic transfer switching solution based on IEC 61850 GOOSE communication simplifies secondary control wiring and enables fast delivery.

# Technical characteristics

UniGear ZS1 is medium voltage switchgear with a metal enclosure, suitable for indoor installations.

Metal partitions segregate the compartments from each other and the live parts are air-insulated. The main technical characteristics are shown as follows.

## Technical characteristics

Product		UniGear ZS1
Rated voltage	[kV]	12
Rated insulation level	[kV]	42/75
Rated busbar current (40°C)	[A]	4000
Rated branch busbar current (40°C)	[A]	630/1250/1600/2000/2500 <sup>1)</sup>
Rated making current	[kA]	...31.5, 40 <sup>1)</sup>
IAC	[kA]	...31.5, 40 (1 s)
Test standard		GB, IEC
Dimensions 	H[mm]	2200 <sup>2)</sup>
	W[mm]	500 /650/800/1000
	D[mm]	1310/1620/1810

Note:

1) If higher rating on request, please contact your ABB sales representative.

2) Depends on the height of low voltage compartment (705/905/1100 mm).

# Design features

## Compartments

Each switchgear unit consists of three power compartments: apparatus, busbars and cables. Each unit is fitted with a low voltage compartment, where all the auxiliary instruments are housed.

Arc-proof switchgear is normally provided with a duct for evacuation of the gases produced by an arc; different types of gas ducts are available.

The compartments are segregated from each other by metallic partitions.

## Main busbars

The busbar compartment contains the main busbar system connected to the upper isolating contacts of the circuit-breaker by means of branch connections.

The main busbars are made of electrolytic copper. For ratings up to 2 500 A, the busbars are flat bars; while for currents between 3 150 A and 4 000 A, a special D-shape busbar is used. Busbar bushings are a standard feature.

## Cable connections

The cable compartment contains the branch system for connection of the power cables to the lower contacts of the circuit-breaker.

The feeder connections are made of electrolytic copper and they are tubular busbars for the whole range of currents.

## Branch busbars

UniGear ZS1 uses tubular branch copper bar to optimize the electric field strength of the main circuit. Compared to rectangular copper bar with the same current class, the air clearances between phases and phase to ground are increased. Combination with the optimized electric field design, the maximum electric field strength is significantly reduced. Without additional heat shrinkable sleeves and insulation covers, UniGear ZS1 still maintains sufficient insulation margins.

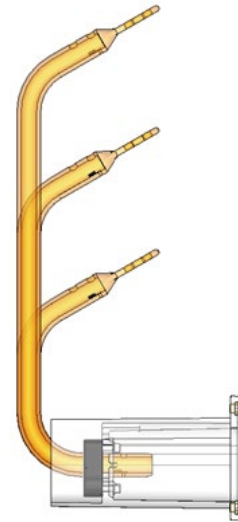

## Earthing switch

Cable compartment can be fitted with an earthing switch for cable earthing.

The same device can also be used to earth the busbar system (measurements and bus-tie units). It can also be installed directly on the main busbar system in a dedicated compartment (busbar applications).

The earthing switch has short-circuit making capacity.

Control of the earthing switch is from the front of the switchgear with manual operation, and optionally, can also be motor operated.

## Earthing busbar

The earthing busbar is made of electrolytic copper and it runs longitudinally throughout the switchgear, thereby guaranteeing maximum personnel and installation safety.

## Insulating bushings and shutters

The insulating bushings in the circuit-breaker compartment contain the contacts for connection of the circuit-breaker with the busbar compartment and cable compartment respectively.

The shutters are metallic and are activated automatically during movement of the circuitbreaker from the racked-out position to the operation position and vice versa.

#### Cables

Single and three-core cables up to a maximum of six per phase can be used depending on the rated voltage, the unit dimensions and the cable cross section.

#### Gas exhaust duct

The gas exhaust duct is positioned above the switchgear and runs along its whole length. Each power compartment is fitted with a flap on its top surface. The pressure generated by the fault makes it open, allowing the gas to pass into the duct.

Evacuation from the room of the hot gases and incandescent particles produced by the internal arc must normally be carried out.

The UniGear ZS1 switchgear can be fitted with a complete range of solutions to satisfy all requirements, either in the case where evacuation is possible directly at the end of the switchgear, or when solutions from the front or rear are requested.

Please contact your ABB sales representative for more information.

#### Busbar applications

Each switchgear unit can optionally be fitted with an accessory busbar application:

Current or voltage transformers for busbar measurements

Busbar system earthing switch

Top entry duct or cables to make interconnections between different sections of switchgear

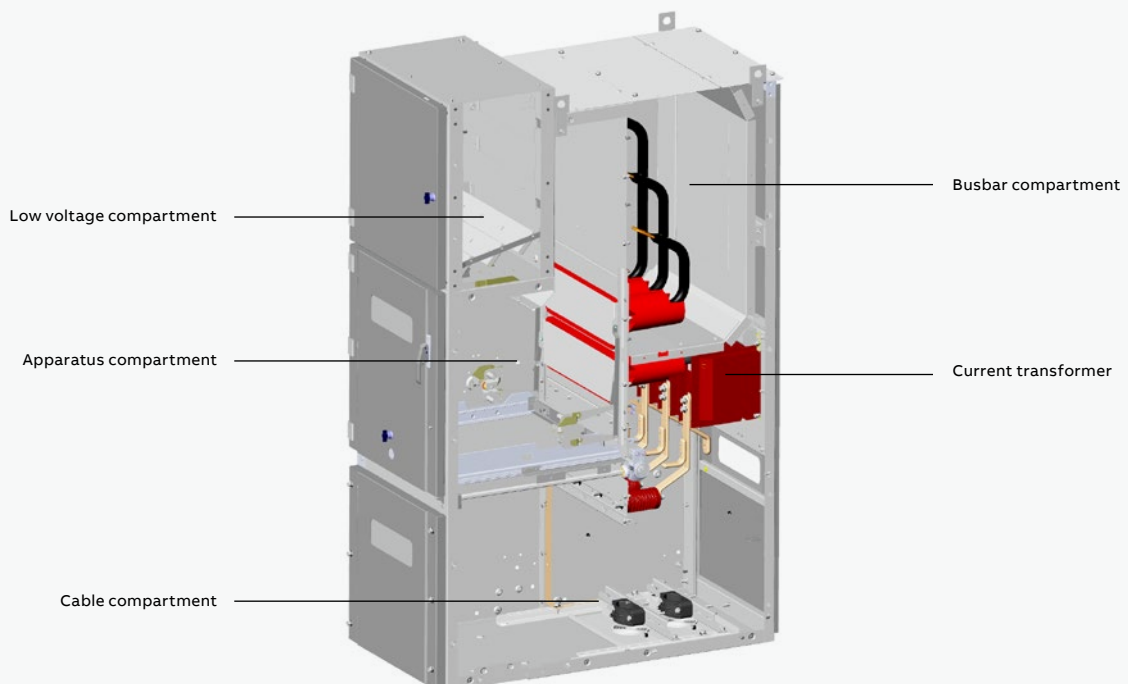

# Fully type-tested

The UniGear ZS1 switchgear has undergone all the tests required by the international (IEC) Standards and local Standards organizations (for example, the Chinese GB, DL and NB standards).

As indicated in these standards, the tests were carried out on the switchgear units considered most sensitive to the effects of the tests and therefore the results were extended across the whole range.

Each switchgear unit is subjected to routine tests in the factory before delivery.

These tests are intended to provide a functional check of the switchgear based on the specific characteristics of each installation.

## IEC type tests

- Short-time and peak withstand current
- Temperature rise
- Internal arc capability
- Dielectric test
- Making and breaking capacity of circuit-breaker and contactors
- Earthing switch making capacity
- Mechanical operations of circuit-breaker and earthing switch
- IP protection degree

## IEC routine factor tests

- Visual inspection and check
- Mechanical sequence operations
- Cabling check
- Electrical sequence operations
- Power frequency withstand voltage
- Measurement of the resistance of the main circuits
- Secondary insulation test

## Special type tests

- Condensation test
- Digital solution type test with cubicle

## Description of IEC type tests

### Short-time and peak withstand current

The test shows that the main power and the earthing circuits resist the stresses caused by the passage of the short-circuit current without any damage.

It should also be noted that both the earthing system of the withdrawable circuit-breaker and the earthing busbar of the switchgear are subjected to the test.

The mechanical and electrical properties of the main busbar system and of the top and bottom branch connections remain unchanged even in the case of a short-circuit.

### Temperature rise

The temperature rise test is carried out at the rated current value of the switchgear unit and shows that the temperature does not become excessive in any part of the switchgear unit. During the test, both the switchgear and the circuit-breaker or contactor it may be fitted with are checked.

### Internal arc capability

Please refer to chapter Safety

### Dielectric test

These tests verify that the switchgear has sufficient capability to withstand the lightning impulse and the power frequency voltage. The power frequency withstand voltage test is carried out as a type test, but it is also a routine test on every switchgear unit manufactured.

### Circuit-breaker making and breaking capacity

The circuit-breaker or contactor is subjected to the rated current and short-circuit current breaking tests.

Furthermore, it is also subjected to the opening and closing of capacitive and inductive loads, capacitor banks and/or cable lines.

### Earthing switch making capacity

The earthing switch of the UniGear ZS1 switchgear can be closed under short-circuit. Although, the earthing switch is normally interlocked to avoid being operated on circuits which are still live.

However, should this happen for any one of several reasons, personnel safety would be fully safeguarded.

**Mechanical operations**

The mechanical endurance tests on all the operating parts ensures the reliability of the apparatus. General experience in the electrotechnical sector shows that mechanical faults are one of the most common causes of a fault in an installation.

The circuit-breaker is tested by carrying out a high number of operations - higher than those which are normally carried out by installations in the field.

Furthermore, the switchgear components are part of a quality control program and samples are regularly taken from the production lines and subjected to mechanical life tests to verify that the quality is identical to that of the components subjected to the type tests.

**IP protection degree**

The IP protection degree is the resistance offered by the UniGear ZS1 against penetration of solid objects and liquids.

This degree of resistance is indicated by the prefix IP followed by two characters (i.e. IP4X). The first number identifies the degree of protection against the entrance of solid objects, the second one is related to liquids.

**Condensation test**

The condensation test demonstrates the dielectrical performance of the UniGear ZS1 switchgear in harsh environments. The relevant criteria for the condensation test is as follows:

- The prototype is left in an environment with a relative humidity of 100% for more than 12 hours.
- Before the test, a uniform distribution of unconnected water droplets is formed on the outer insulation surface.
- The test voltage is 42/75 kV for power frequency and lightning impulse tests



# Safety

This is why the UniGear ZS1 switchgear has been designed and tested to withstand an internal arc due to a short-circuit current of the same current level as the maximum short-time withstand level. The tests show that the metal housing of UniGear ZS1 switchgear is able to protect personnel near the switchgear in the case of a fault which evolves as far as striking an internal arc.

An internal arc is a highly unlikely fault, although it can theoretically be caused by various factors, such as:

- Insulation defects due to quality deterioration of the components. The reasons can be adverse environmental conditions and a highly polluted atmosphere.
- Overvoltages of atmospheric origin or generated by the operation of a component
- Inadequate training of the personnel in charge of the installation
- Breakage or tampering of the safety interlocks
- Overheating of the contact area, due to the presence of corrosive agents or when the connections are not sufficiently tightened
- Entry of small animals into the switchgear (i.e. through cable entrance)
- Material left behind inside the switchgear during maintenance activities

The characteristics of the UniGear ZS1 switchgear notably reduce the incidence of these causes for faults, but some of them may not be eliminated completely.

The energy produced by the internal arc causes the following phenomena:

- Increase in the internal pressure
- Increase in temperature
- Visual and acoustic effects
- Mechanical stresses on the switchgear structure
- Melting, decomposition and evaporation of materials

Unless suitably protected, these phenomena have very serious consequences for the personnel, such as wounds (due to the shock wave, flying parts and the doors opening) and burns (due to emission of hot gases).

The internal arc test verifies that the compartment doors remain closed and that no components are ejected from the switchgear even when subjected to very high pressures, and that no flames or incandescent gases penetrate, thereby ensuring safety of the personnel near the switchgear.

The test also ensure that no holes are produced in external accessible parts of the housing, and finally, that all the connections to the earthing circuit remain intact, hence guaranteeing the safety of personnel who may access the switchgear after the fault.

The IEC 62271-200 Standard describes the methods to be used for carrying out the test and the criteria which the switchgear must conform to.

The UniGear ZS1 switchgear fully conforms to all the five criteria indicated by the IEC standards.

The IAC classification is proved by the test according to the following designations:

- General: classification IAC (Internal Arc Classified)
- Accessibility: A, B or C (switchgear accessible to authorized personnel only (A), to all (B), not accessible due to installation (C))
- F, L, R: access from the front (F – Front), from the sides (L – Lateral) and from the rear (R – rear)
- Test values: test current in kiloamperes (kA), and duration in seconds (s)

The parameters of each specific plant mean that evacuation of the hot gases and incandescent particles must be checked very carefully in order to ensure and maintain personnel safety.

## Fault limiting systems

The structure of the UniGear ZS1 switchgear offers complete passive type protection against the effects of a fault due to an internal arc for a time of 1 second up to 40 kA.

ABB has also developed excellent active protection systems which allow very important objectives to be achieved:

- Detection and extinction of the fault, normally in less than 100 ms, which improves network

stability

- Limitation of damage on the apparatus
- Limitation of outage time for the switchgear unit

For active protection against an internal arc, devices consisting of various types of sensors can be installed in the various compartments, which detect the immediate outburst of the fault and carry out selective tripping of the circuitbreakers.

The fault limiting systems are based on sensors which use the pressure or light generated by the arc fault as trigger for fault disconnection.

#### ITH

The ITH sensors consist of micro-switches positioned on the top of the switchgear near the gas exhaust flaps of the three power compartments (busbars, circuit-breaker and cables).

The shock wave makes the flaps open and operate the micro-switches connected to the shunt opening release of the circuit-breaker. Total tripping time is 75 ms (15 ms ITH + 60 ms circuit-breaker).

#### TVOC

This system consists of an electronic monitoring device located in the low voltage compartment which is connected to optic sensors. These are distributed in the power compartments and are connected to the device by means of optic fibres. When a certain pre-set light level is exceeded, the device opens the circuit-breakers.

To prevent the system from intervening due to light occasionally generated by external phenomena (flash of a camera, reflections of external lights, etc.), current transformers can also be connected to the monitoring device.

The protection module only sends the opening command to the circuit-breaker if it receives the light and short-circuit current signal simultaneously.

Total tripping time is 62 ms (2 ms TVOC + 60 ms circuit-breaker).

#### REA

This system offers the same functionality as TVOC. The REA system consists of the main unit (REA 101) and optional extension units (REA 103, 105, 107) which make it possible to create customized solutions with selective tripping. Total tripping time is 62,5 ms (2,5 ms REA + 60 ms circuit-breaker).

#### Arc protection in IED

615 series, 620 series and REX640 IEDs (Intelligent Electronic Device) can optionally be fitted with a fast and selective arc flash protection. It offers a two-to three-channel arcfault protection system for arc flash supervision of the circuit breaker, cable and busbar compartment of switchgear panels. Total tripping time is 72 ms (12 ms IED + 60 ms circuit-breaker).

#### UFES (ultra fast earthing switch)

The UFES is an innovative design of an extremely fast-acting earthing switch, grounding all 3 phases within < 4 ms after detection of an internal arc fault.

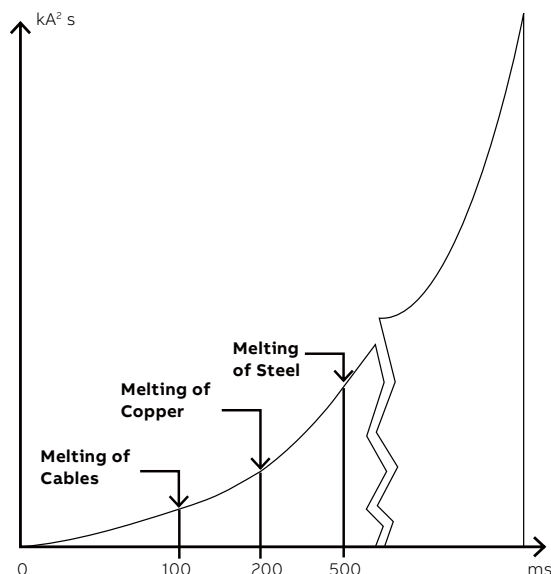

# Safety

## **Interlocks**

The safety mechanical interlocks are standard ones, please see the dedicated table on nextpage. They are set out by the IEC standards and are therefore necessary to guarantee the correct operation sequence.

ABB safety interlocks guarantees the highest level of reliability, even in the case of an accidental error, and enables highest operator safety system of interlocks.

## **Padlocks**

The apparatus [6] and cables [7] compartment doors can be locked in the closed position by means of padlocks. These can be applied to both door closing versions –with central handle (standard) or screws (optional). The operations for apparatus racking-in/out [8] and earthing switch opening/closing [9] can be prevented by applying the padlocks to the insertion slots of the relevant operating levers. The padlock can also be applied to the earthing switch of busbar applications.

The metallic segregation shutters [10] between apparatus, busbars and cables compartments can be locked by means of two independent padlocks in both the open and closed positions. Padlocks from 5 to 8 mm diameter can be accommodated.

## **Locking magnets**

The locking magnets enable automatic interlocking logics without human intervention. The apparatus racking-in/out [11] and the earthing switch closing/opening [12] operations can be interlocked.

The apparatus [13] and cables [14] compartment doors operation can be interlocked.

**Standard safety interlocks (mandatory)**

Type	Description	Condition to be met
1	A Apparatus racking-in/out	Apparatus in open position
	B Apparatus closing	Defined truck position
2	A (optional) Apparatus racking-in	Apparatus multi-contact plug plugged
	B (optional) Apparatus multi-contact plug unplugging	Truck in test position
3	A Earthing switch closing	Truck in test position
	B Apparatus racking-in	Earthing switch in open position
4	A Apparatus compartment door opening	Truck in test position
	B Apparatus racking-in	Apparatus compartment door closed
5	A Cable compartment door opening	Earthing switch in ON position
	B Earthing switch opening	Cable compartment door closed

Note: Apparatus are circuit-breakers and contactors.

**Padlocks (on request)**

6	Apparatus compartment door opening
7	Cable compartment door opening
8	Insertion of the apparatus racking-in/out crank lever
9	Insertion of the earthing switch operating lever
10	Shutters opening or closing

**Locking magnets (on request)**

11	Apparatus racking-in/out
12	Earthing switch ON/OFF
13	Apparatus compartment door opening
14	Cable compartment door opening

**Accessory devices**

15	Shutters fail-safe	The device locks the shutters in the closed position when the apparatus is removed from the compartment. The operator cannot open the shutters manually. The shutters can only be operated by the apparatus truck or the service trucks.
16	Apparatus-switchgear unit compatibility matrix	The apparatus multi-contact plug and relative switchgear unit socket are equipped with a mechanical matrix, that disables apparatus racking-in into a switchgear unit with an inappropriate rated current.
17	Circuit-breaker mechanical operating mechanism	The apparatus compartment is equipped with a mechanical device, that enables circuit-breaker closing and/or opening directly by means of the front operating mechanism push buttons, keeping the door closed. The controls can be operated with the circuit-breakers in the operation and racked-out position.

# Vacuum circuit-breaker

UniGear ZS1 switchgear can be fitted with the widest range of apparatus available on the market today, and of these the vacuum circuitbreaker now occupies a position of prime importance in all sectors of primary distribution. Vacuum circuit-breakers cover the whole range of switchgear parameters and therefore the whole range of applications.

Many years of experience gained in developing and using vacuum interrupters is today reflected in the range of ABB circuit-breakers, which stand out for their exceptional electrical and mechanical characteristics, extremely long life, low maintenance, compactness and the use of highly innovative construction techniques.

ABB develops and produces a complete range of interrupters for use in circuit-breakers and contactors and for all medium voltage applications.

## VD4 circuit-breaker

The VD4 medium voltage circuit-breaker interrupters use vacuum to extinguish the electric arc and as the insulating medium. Thanks to the unequalled properties of vacuum and the breaking technique used, current interruption takes place without arc chopping and without overvoltages. Restoration of the dielectric properties following interruption is extremely rapid.



The VD4 circuit-breakers are used for protection of cables, overhead lines, motors, transformers, generators and capacitor banks.

## Poles

The VD4 medium voltage circuit-breakers use vacuum interrupters embedded in poles. Embedding the interrupter in the pole makes the circuit-breaker particularly sturdy and protects the interrupter itself against shocks, deposits of dust and humidity.

The vacuum interrupter houses the contacts and provides the interruption chamber.

ABB circuit-breakers use the most advanced vacuum-breaking techniques: with radial magnetic flow for circuit-breakers with mediumlow ratings and with axialmagnetic flow for those with high breaking capacity.

Both techniques guarantee even distribution of the arc roots over the whole surface of the contacts, allowing optimum performance at all current values.

The structure of a vacuum interrupter is relatively simple. The housing is made up of a ceramic insulator closed at the ends by stainless steel covers. The contacts are made of pure copper and sintered chrome and are welded to the copper terminals. A metallic bellows allows movement of the moving contact-terminal group, at the same time guaranteeing that the vacuum is maintained in the interrupter. The interrupter components are welded in an environment under a very strong vacuum to guarantee a vacuum of less than 10-5 Pa in the interrupter.

This means that the interrupter does not any ionisable material. In any case, on detachment of the contacts, an electric arc is generated which only consists of the melted and vaporised material of the contact.

A metallic shield is integrated inside the interrupter to capture the metallic vapours given off during interruption, as well as for controlling the electric field. The particular shape of the contacts generates a magnetic field which forces the arc to rotate and to involve a much wider surface than that of a fixed contact arc.

Apart from limiting the thermal stress on the contacts, this makes contact erosion negligible and, above all, allows the interruption process to be controlled even with very high short-circuit currents.

The electric arc remains supported by the external energy until the current passes through its natural zero.

The ABB vacuum interrupters are zero current interrupters and are free of any re-striking phenomena.

The rapid reduction of the current density and fast condensation of the metallic vapours, that happens at the instant that the current passes through zero, allow the maximum dielectric strength between the interrupter contacts to be re-established within a few milliseconds. Supervision of the vacuum level is not necessary as the circuit-breaker poles are sealed-for-life and do not require any maintenance.

#### **Operating mechanism**

The VD4 circuit-breaker is fitted with a mechanical stored energy type operating mechanism.

The trip free mechanism allows opening and closing operations independent of the operator. The operating mechanism spring system can be recharged either manually or by means of a geared motor. The apparatus can be opened and closed by means of the pushbuttons on the front of the operating mechanism or by means of electric releases (shunt closing, shunt opening and undervoltage).

The circuit-breakers are always fitted with an anti-pumping device to eliminate the possibility of simultaneous opening and closing commands, closing commands with springs discharged or with the main contacts not yet in their run-end position.

#### **Truck**

The poles and operating mechanism are fixed onto a metal support and handling truck.

The truck is provided with a wheel system which makes the operations for racking the apparatus into and out of the switchgear unit possible with the door closed. The truck allows efficient earthing of the circuit-breaker by means of the metallic structure of the switchgear unit.

The vacuum circuit-breaker truck can be motor-operated.

The racking-out and racking-in operations can be carried out by means of electrical controls, either locally by the operator or by a remote system.

#### **Apparatus-operator interface**

- The front part of the circuit-breaker provides the user interface. It features the following equipment:
- ON pushbutton
- OFF pushbutton
- Operation counter
- Indicator of the circuit-breaker open and closed state
- Indicator of the charged or discharged state of the operating mechanism springs
- Manual charging device for the operating mechanism springs
- Override selector of the undervoltage release (optional)

#### **Standards**

- IEC 62271-100 for the circuit-breaker

# ConVac vacuum contactor

- 1 Front view
- 2 Rear view
- 3 Vacuum interrupter



1



2



3

The medium voltage ConVac contactor operates in alternating current and is normally used to control devices requiring a high number of hourly operating sequences.

The ConVac contactor has a linear electromagnetic actuator that moves in line with the moving contact of the vacuum interrupters to guarantee the best performance and long, reliable mechanical life.

## Application

The ConVac is widely used in industry, power plant, etc.

ConVac operates reliably under particularly harsh environmental conditions.

The ConVac is ideal for controlling motors, transformers, capacitor banks, switching systems, etc.

Fitted with fuses, they can be used in circuits with up to 50 kA fault levels.

### Standards

The ConVac fully meet the following standards.

- GB/T 14808
- IEC 62271-106

### Operation condition

- Ambient temperature: -15°C...+40°C
- Relative humidity: <95%
- Altitude <1000 m

For different operation condition, please contact your ABB sales representative.

### Main technical characteristics

- Low chopping current value:  $\leq 0.5$  A
- Maintenance-free
- Suitable for frequent operation
- High mechanical and electrical life
- Multi-voltage feeder

### Two different type of actuating system:

- **Electrical latching:** closing takes place by supplying auxiliary power to the multi-voltage feeder. On the other hand, opening occurs when the auxiliary power is interrupted either intentionally (by means of a command) or unintentionally (due to lack of auxiliary power in the installation).
- **Mechanical latching:** the contactor closes as in the electrical latching version but when the apparatus reaches the closed position, this is maintained by a mechanical device. Opening takes place when the opening coil is supplied. This releases the mechanical lock and allows the opening springs to operate.

Mechanical latching is achieved only by assembling on the electrically latched version a kit, called RiMe. In the same way, removing the kit from a mechanically latched unit, is possible to switch to electrical latching. This activity can be done directly by the customer as there is no adjustments required.



<b>ConVac electrical characteristics</b>		<b>7.2 kV</b>
Rated voltage	[kV]	7.2
Rated insulation voltage	[kV]	7.2
Rated power frequency withstand voltage	[kV / 1 min]	20 (32) <sup>(3)</sup>
Rated lightning impulse withstand voltage	[kV]	60
Rated frequency	[Hz]	50 / 60
Rated short-time withstand current <sup>(1)</sup>	[kA]	6 (50)
Internal arc withstand current <sup>(2)</sup>	[kA / 1 s]	...50
Maximum contactor rated current without fuses	[A]	400
Maximum contactor rated current with fuses	[A]	250

(1) Limited by the fuses.

(2) The internal arc withstand values are guaranteed in the compartments on the supply side of the fuses (busbars and apparatus) by the structure of the switchgear and on the load side (feeder) by the limiting properties of the fuses.

(3) Available on request.

# Service trucks

The trucks are divided into four different types:

- Earthing without making capacity
- Earthing with making capacity
- Cable test
- Isolating

## **Earthing truck without making capacity**

These trucks carry out the same function as the earthing switches without making capacity. They therefore have no capacity to earth live circuits in fault conditions.

They are used to ensure an additional fixed earth, as is required by certain installation service and maintenance procedures, as a further safety guarantee for personnel.

The use of these trucks require the removal of the apparatus (circuit-breaker or contactor) from the switchgear and its replacement with the truck. The switchgear panels preset for use of the earthing trucks must be provided with a key lock which, when activated, prevents their racking-in.

This truck is available in two versions:

- Earthing of the main busbar system
- Earthing of the power cables

The earthing truck of the main busbars, during the racking-in phase, only lifts the top shutter and earths the contacts connected to the top branch connections (and therefore to the main busbar system) by means of the switchgear structure.

The earthing truck of the power cables, during the racking-in phase, only activates the bottom shutter and earths the contacts connected to the bottom branch connections (and therefore to the power cables) by means of the switchgear structure.

These trucks can also be used in the bus-tie unit. In this case, they earth one of the two sides of the main busbar system.

## **Earthing truck with making capacity**

These trucks carry out the same function as the earthing switches with making capacity.

They consist of circuit-breakers provided with top (earthing of the main busbars) or bottom (earthing of the power cables) terminals only. The contacts without terminals are short-circuited by means of a copper bar and connected to earth by means of the apparatus truck.

They keep all the characteristics of the circuitbreakers, such as full making and breaking capacity on live circuits under fault conditions. They are used to ensure extremely effective earthing on circuits stressed by a fault. They allow opening and closing operations to be carried out rapidly with electric remote control.

The use of these trucks require the removal of the apparatus (circuit-breaker or contactor) from the switchgear and its replacement with the truck. The switchgear panels preset for use of the earthing trucks must be provided with a key lock which, when activated, prevents their being racked-in.

This truck is available in two versions:

- Earthing of the main busbar system
- Earthing of the power cables

The earthing truck of the main busbars, during the racking-in phase, only lifts the top shutter and presets the contacts connected to the top branch connections (and therefore to the main busbar system) for closing to earth by means of operating mechanism.

The earthing truck of the power cables, during the racking-in phase, only activates the bottom shutter and presets the contacts connected to the bottom branch connections (and therefore to the power cables) for closing to earth by means of operating mechanism.

These trucks can also be used in the bus-tie unit. In this case, they earth one of the two sides of the main busbar system.

## **Power cable test truck**

These trucks allow the insulation tests on the power cables to be carried out without accessing the cable compartment or disconnecting the cables from the switchgear.

The use of these trucks require the removal of the apparatus (circuit-breaker or contactor) from the switchgear and its replacement with the truck. The truck, during the racking-in phase, only activates the bottom shutter and, by means of the connectors it is fitted with, allows connection of the test apparatus cables.

This truck can only be used in the incoming/outgoing feeders with the door open.

**Isolating truck**

The isolating truck allows the top switchgear contacts to be connected directly to the bottom ones. Connection is made extremely safe by using the poles of the circuit-breakers to insulate the connection busbars from the external.

environment. In the incoming/outgoing feeder units it connects the main busbar system to the power cables, whereas in the bus-tie, to the two sides of the busbar system.

This truck has its application in UniGear switchgear for making incoming/outgoing feeders without a circuit-breaker in radial networks, for making cable connections between two items of switchgear placed in front of each other, in making interconnection units and in creating the bus-tie riser configuration with double insulation (in this case, both the units are made up of bus-ties, the former fitted with a circuit-breaker and the latter with an isolating truck).

The switchgear panels preset for use of the isolating trucks must be fitted with a key lock which, when activated, prevents their being racked-in.

Main busbar system earthing truck, without making capacity.

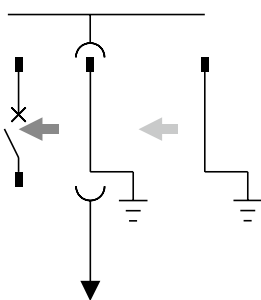

Power cable earthing truck, without making capacity.

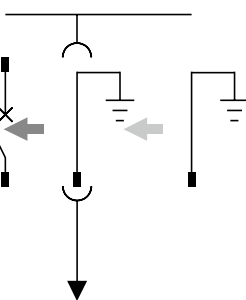

Cable test truck.

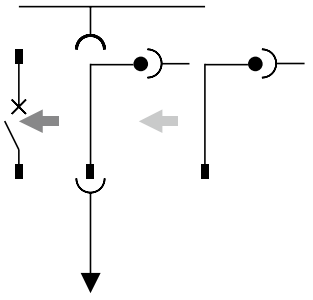

Main busbar system earthing truck, with making capacity.

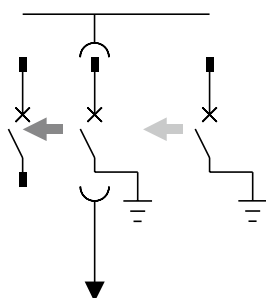

Power cable earthing truck, with making capacity.

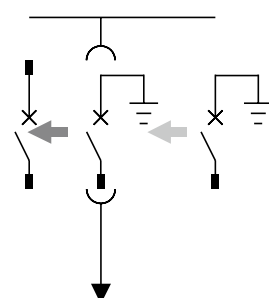

Isolating truck.

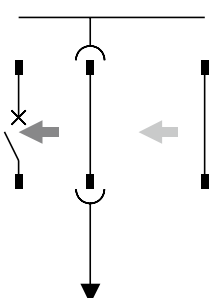

# Instrument transformers

- 
- 1 1250 A CT
- 
- 2 2500 A CT

## Current transformer

The block type current transformers are epoxy resin insulated and used to supply the measurement devices and protection instruments. These transformers can have a wound core or a bushing bar with one or more cores, with performance and accuracy classes suitable for the installation requirements.

They conform to the IEC 61869-1, IEC 61869-2 which have fully replaced previous standard IEC 60044-1.

Their dimensions are in accordance with the DIN 42600 Standard, in the Medium and Long Size versions up to 2 500 A.

The current transformers are normally fitted on the load side of the apparatus compartment for measurement of the phase currents of the switchgear unit. Fitting on the supply side of the apparatus compartment is also possible (busbar applications) for measuring the busbar currents or for realising particular protection schemes.



—  
1

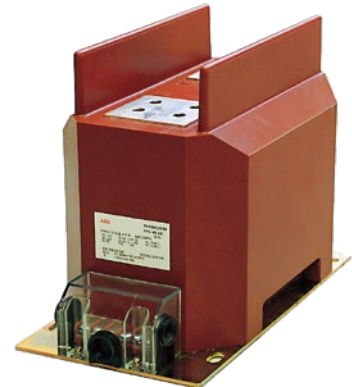

—  
2

- 
- 1 One pole VT
- 
- 2 Two poles VT
- 
- 3 One pole VT with fuse
- 
- 4 Withdrawable truck VT with fuse

### Voltage transformer

The voltage transformers are of the epoxy resin insulated type and are used to supply measurement and protection devices.

They are available for fixed assembly or for installation on removable and withdrawable trucks.

Their dimensions are in accordance with the DIN 42600 Standard.

They conform to the IEC 61869-1, IEC 61869-3 which have fully replaced previous standard IEC 60044-2.

These transformers can have one or two poles, with performance and precision classes suited to the functional requirements of the instruments connected to them.

When they are installed on removable or withdrawable trucks they are fitted with medium voltage protection fuses.

The withdrawable trucks also allow replacement of the fuses with the switchgear in service. Truck racking-out with the door closed automatically operates closure of a metallic segregation shutter between the live parts of the switchgear and the instrument compartment.

Fixed voltage transformers can be installed directly on the main busbar system in a dedicated compartment (busbar applications).



1



2



3



4

# Cable terminations

## **Terminations for polymer insulated cables 1 – 24 kV**

It is crucial that power cables connecting the switchgear are terminated properly, and for this purpose, ABB has developed an excellent range of easy-to-use products for preparation and termination of cables.

MV power cables are normally designed with a conductor of aluminium or copper, an insulation of polymer material, an extruded insulation screen, a metallic screen, armouring (optional) and a polymeric outer jacket.

To enable safe and reliable current carrying properties, it is necessary to achieve sufficient mechanical connection between the cable conductor and the bus bar. ABB offers mechanical cable lugs designed to fit the cable conductor by bolting. It is also essential to guide the electrical field of the cable correctly, and ABB offers Cold Applied terminations, made of rubber, that create an active pressure around the cable. Furthermore, if the cable is designed with another type of metallic screen than copper wires, special earthing kits must be used to achieve proper handling of possible fault currents. The armouring of the cable must have the same earth potential as the cable screen, so it might be necessary to use additional connection accessories that are also available. Detailed information can be found in separate technical information for cable accessories.

## **Applications and features**

Depending on the cable design, it is necessary to use the correct type of cable accessory. When single core cables are designed with copper wire screen only, it is sufficient to use just a cable lug and a termination that fits the actual size of the cable.

The benefit of Cold Applied accessories is that no heat or open flame is necessary for installation (except for branch seals on 3-core cables). After the cable is prepared, the termination is simply slid on without any tools. If a three core cable is used, or a cable with copper tape screen, or aluminium foil screen, or a cable with armouring; then additional material is required.

Another very important factor is correct cable preparation, and ABB also offers excellent cable preparation tools.

## **Recommended cable termination products**

The pre-moulded cable termination type SOT can be used on any polymer cable irrespective of design or conductor size. Type SOT 10 is designed for 7.2 kV cables, while type SOT 24 covers 12, 17.5 and 24 kV. A few variants of terminations fit a wide range of cable sizes. Extra material such as earthing kits, crutch seals for 3-core cables and screen potential material for cable armouring is also covered by the ABB range of products. Please contact your ABB Sales Representative for more information.

—  
01 Cable termination type  
SOT 10 with bi-metallic  
cable lug type SKSB

—  
02 Cable termination  
type SOT 24 with bi-  
metallic cable lug type  
SKSB

01



02



### Designation and sizes

Voltage level [kV]	Designation	Diameter over insulation [mm]	Conductor size [mm <sup>2</sup> ]			
			7.2 kV	12 kV	17.5 kV	24 kV
1-7.2	SOT 101	10.5-15	10-35	-	-	-
1-7.2	SOT 102	12.9-25.8	50-150	-	-	-
1-7.2	SOT 103	21.4-34.9	185-300	-	-	-
12-17.5	SOT 241 A	11-15	-	10-35	-	-
12-17.5	SOT 241	15-28	-	50-185	50-150	-
12-17.5	SOT 242	24-39	-	240-500	185-300	-
24	-	-	-	-	-	-
12-17.5	SOT 241 B	38-54	-	630(*)	630(*)	-
24	SOT 241 A	11-15	-	-	-	10
24	SOT 241	15-28	-	-	-	25-120
24	SOT 242	24-39	-	-	-	150-400
24	SOT 242 B	38-54	-	-	-	500-630(*)

(\*) Can be mounted on cables with 800 and 1000 mm<sup>2</sup> by using silicone rubber tape 2342 as top seal.

# Distribution automation

## **ABB's power protection philosophy**

Having delivered protection relays to more than 100 countries, ABB fully understands the need for diverse protection philosophies that meet local legislation, safety requirements and engineering practice. Therefore, ABB has developed a power protection philosophy that not only serves the specific needs and requirements of diverse power systems, but also creates confidence and peace of mind for both the power system owners and users.

The main purpose of a protection relay system is to recognize any abnormal power system condition(s), or abnormally operating system component(s). Based on the information gathered, the protection system will initiate corrective actions that return the system to its normal operating state. This provides a safe environment for all.

Protection relays are activated when something abnormal has happened in the power system; they do not prevent network faults from arising. Selecting the right protection functions and methods improves the performance and the reliability of the protection system, thus minimizing the effects of network faults and preventing the disturbance from spreading to the healthy parts of the network.

## **Advantages of a complete protection system**

Close attention must be paid to operating speed, sensitivity, selectivity and reliability of the protection system. There is a strong correlation between the operating speed of the protection system and the damage and danger caused by a network fault. Substation automation provides remote control and monitoring capabilities, which speed up the location of faults and the restoration of the power supply. Fast operation of the protection relays also minimizes post-fault load peaks. Together with voltage dips, post-fault load peaks increase the risk of the disturbance spreading to healthy parts of the network. The sensitivity of the protection must be adequate to detect relatively high resistance earth faults and short-circuits in the most distant parts of the network. Reliable selectivity is essential to limit the loss of power supply to as small a part of the network as possible, and to allow the faulted part of the network to be reliably located. Corrective actions can then be directed to the faulty part of the network, so that the power supply can be restored as quickly as possible.

The protection system must have a high degree of reliability. This also means that if, for example, the circuit breaker (CB) fails to operate, the back-up protection will clear the fault. Substation automation (SA) puts the operator in complete control of the substation. In addition, SA improves the power quality of the transmission and distribution network under normal operation, but especially in a disturbance situation and during substation maintenance activities. An SA or SCADA brings the full benefits of digital technology into protection and control of the networks. The protection relays are easily set-up and parameterized through easy and safe access from the operator's workplace.

# Distribution automation

## **Relion® protection and control relays**

The Relion® product family offers the widest range of products for the protection, control, measurement and supervision of power systems for IEC and ANSI applications – from generation and interconnected transmission grids over primary distribution to secondary distribution kiosks.

The Relion protection relays are deeply rooted in ABB's vast experience of developing successful protection and control relays. These relays have been developed during many years and are built on the experience gathered from wide ranging application and functionality requirements of ABB's customers globally.

To ensure interoperable and future-proof solutions, Relion products have been designed to implement the core values of the IEC 61850 standard. The genuine implementation of the IEC 61850 substation modelling and communication standard covers both vertical and horizontal information exchange between protection relays and external systems. The protection and control IED manager PCM600 provides versatile functionality throughout the life cycle of all Relion protection and control relays. PCM600 is IEC 61850 compliant, which ensures smooth engineering of the relays and enables information exchange with other IEC 61850 compliant tools.

With these products, you benefit from ABB's leading-edge technology, global application knowledge and experienced support network. The Relion technology is leading the way and setting the future trends in the field of protection and control systems.

## **Relion 605 series**

The Relion 605 series protection relays feature basic devices that fulfill the essential protection needs in medium-voltage networks. The series is best suited for secondary distribution applications. These relays are well-known for their straight forward approach to protection.

## **Relion 611 series**

The Relion 611 series protection relays are powerful and very easy-to-use protection devices in a compact design. The 611 series relays are delivered with a pre-configured application, which can be adapted, to a limited extent, to application-specific needs. The series offers preconfigured solutions, which are ideally suited for utility distribution and industrial applications.

## **Relion 615 series**

The Relion 615 series protection relays can be defined as a compact and versatile solution for power distribution in utility and industrial applications. The 615 series provides standard configurations, which allows you to easily adapt and set-up your applications, still allowing you to adapt the configuration according to applicationspecific needs. The 615 series combines compactness and powerful features in one smart package.

## **Relion 620 series**

The Relion 620 series protection relays increase flexibility in demanding utility and industrial applications for power distribution. They are delivered with example configurations to ease adaptation into your specific applications. The series offers customization possibilities, which supports higher levels of standardization in the applications. The 620 series extends the hardware possibilities further compared to the 615 series.

—  
01 Relion protection and control product family

### Relion 630 series

The pre-configured Relion 630 series protection relays feature flexible and scalable functionality to adapt to different needs in power distribution networks and industrial applications. The 630 series protection relays contain pre-configured application configurations, which can be freely tailored to meet specific requirements for distribution applications.

### Relion 640

REX640 makes protecting all your assets in advanced power generation and distribution applications easy. The fully modular design allows unequalled customization and modification flexibility, and easy adaptation to changing protection requirements throughout the relay life cycle. This is asset management at its best. Please see dedicated chapter on page 64.

### Relion 650 series

The Relion 650 series offers ease of use from ready-to-use solutions. The 650 series protection relays provide optimum 'off-the-shelf' solutions. These relays are equipped and configured with complete protection functionality and default parameters to meet the needs of a wide range of applications within generation, transmission and sub-transmission.

### Relion 670 series

The Relion 670 series protection and control relays provide versatile functionality, as well as maximum flexibility and performance to meet the highest requirements of any application in generation, transmission and sub-transmission protection systems. The 670 series relays are available as pre-configured and fully customized relays.



—  
01

# Distribution automation

## Feeder protection

Feeder protection, or more exactly protection for overhead lines and cables, is the most used type of protection in power systems. The protection has to ensure that the power grid continues to supply energy. In the event of a fault, it has to be prevented from spreading to healthy parts of the network. The relays also have to minimize the damage to the cables and other connected equipment, as well as ensure safety for operating personnel.

ABB has a large number of feeder protection relays. There are several multifunctional protection relays for different application ranges. Among the protection relays there are some used for general feeder protection (protection against overcurrent) and as back-up protection. There are also more specialized relays, for example, for line differential protection.

The selected protection scheme has to fulfill the application specific requirements regarding sensitivity, selectivity and operating speed. The protection requirements are mainly determined by the physical structure of the network. In most cases the requirements, listed above, can be fulfilled with non-directional/directional overcurrent protection functions.

In power networks with a more complex structure, more advanced protection functions, such as, distance protection or line differential protection, may have to be introduced. The purpose of the over and undervoltage protection system is to monitor the network's voltage level. If the voltage level deviates from the target value by more than the permitted margin for a specific time period, the voltage protection system limits the duration of the abnormal condition and the stresses caused to the power system or its components.

To prevent major outages due to frequency disturbances, sub-stations are usually equipped with underfrequency protection relays, which in turn, control various load-shedding schemes. A specific area for applying line differential protection is emerging with feeder applications

requiring an absolutely selective unit protection system. The zone-of-protection for a line differential protection system is the feeder section, defined by the location between the current measurement devices (current transformers or Rogowski coils). In certain cases there can be a power transformer within the protection zone. Unit protection guarantees exact and fast isolation of the fault and allows continued operation of the unaffected part of the power network.

These are just a few examples of the major protection functions for feeders. More details can be found in the technical documentation available online for ABB's protection and control devices.

## Product offering

The recommended products for feeder protection are part of ABB's Relion® product family. The Relion product family offers the widest range of products for the protection, control, measurement and supervision of power systems for IEC and ANSI applications.

### Relion 605 series

The Relion 605 series protection relays feature basic devices that fulfill the essential protection needs in medium-voltage networks. These relays are well-known for their straight forward approach to protection.

### Relion 611 series

The Relion 611 series offers a pre-configured solution for power distribution in utility and industrial applications. The series is a suitable choice for protection and control of standard feeders. The protection relays are delivered preconfigured for easier and faster relay engineering and shorter time-to-operation.

### Relion 615 series

The Relion 615 series offers a compact and versatile solution for power distribution in utility and industrial applications. The protection relays are delivered with a standard configuration for easier and faster relay engineering and shorter time-to-operation.

- 01 Basic range: Feeder protection REF601 and self-powered feeder protection REJ603
- 02 Medium range: Feeder protection and control REF611, Feeder protection and control REF615
- 03 High range: Feeder protection and control REF620, Feeder protection and control REF630
- 04 Multiapplication Protection and Control REX640

**Relion 620 series**

The Relion 620 series offers flexibility and performance for demanding power distribution in utility and industrial applications. The series offers wider application coverage in one product compared to the 615 series, which enables wider standardization of the product type in your application. The 620 series protection relays are delivered with an example configuration, which helps adaptation to user specific requirements.

**Relion 630 series**

The Relion 630 series protection relays feature flexible and scalable functionality to adapt to different needs in power distribution networks and industrial applications. The relays contain pre-configured application configurations, which can be tailored to meet the specific requirements for also the most demanding distribution applications.

**Relion 640**

The base functionality in REX640 can be enhanced with additional application packages for feeder protection, such as fault locator, line differential protection and line distance protection.

Please see dedicated chapter on page 64.

For more information, please refer to the following documentation:

- Feeder Protection REF601 Product Guide
- Self-Powered Feeder Protection REJ603 Product Guide
- Feeder Protection and Control REF611 Product Guide
- Line Differential Protection and Control RED615 Product Guide
- Feeder Protection and Control REF615 Product Guide
- Feeder Protection and Control REF620 Product Guide
- Feeder Protection and Control REF630 Product Guide
- Multiapplication Protection and Control REX640 Product Guide



01



03



02



04

# Distribution automation

## Transformer protection

The power transformer is an important component and one of the most valuable discrete units in power distribution networks. High availability of the power transformer is of particular importance for preventing disturbances in the power distribution system.

Although high-quality power transformers are very reliable, insulation breakdown faults occasionally occur. These faults appear as short circuits and/or earth faults. They tend to cause severe damage to the windings and transformer core. The damage is proportional to the fault clearing time, so the power transformer must be disconnected as quickly as possible.

For repair, the power transformer has to be transported to a workshop, which is a very timeconsuming process. The operation of a power network, where the power transformer is out of service, is always cumbersome. Therefore, a power transformer fault often constitutes a more severe power system fault than a line fault, which usually can be rectified rather quickly. It is extremely important that fast and reliable protection relays are used to detect transformer faults and initiate tripping.

The size, voltage level and importance of the power transformer determine the extent and choice of monitoring and protection devices to be used to limit the damage, when a fault occurs. Compared to the total cost of the power transformer and the costs caused by a power transformer fault, the cost of the protection system is negligible.

## Product offering

The recommended products for transformer protection are part of ABB's Relion® product family. The Relion product family offers the widest range of products for the protection, control, measurement and supervision of power systems for IEC and ANSI applications.

## Relion 615 series

The Relion 615 series offers a compact and versatile solution for power distribution in utility and industrial applications. The series covers two winding transformer application and automatic voltage regulator function in separate product types. Each protection relay is delivered with a standard configuration for easier and faster relay engineering and shorter time-to-operation.

## Relion 620 series

The Relion 620 series offers flexibility and performance for demanding power distribution in utility and industrial applications. The series offers wider application coverage, including transformer application and automatic voltage regulator, in one product. Compared to the 615 series, it enables wider standardization of the product type in the application. The 620 series relays are delivered with an example configuration, which can be pre-adapted to user specific requirements.

## Relion 630 series

The Relion 630 series protection relays feature flexible and scalable functionality to adapt to different needs in power distribution networks and industrial applications. The relays contain pre-configured application configurations, which can be tailored to meet the specific requirements for also the most demanding distribution applications. In one easily scalable hardware solution, it includes extensive transformer protection and automatic voltage regulator functions.

## Relion 640

The modular design allows customization and modification flexibility, and easy adaptation to changing protection requirements. The relay can be used for two and three-winding transformer applications. The base functionality is enhanced with power transformer application packages. With the packages also on-load tap changer control can be managed. Please see dedicated chapter on page 64.

—  
 01 Transformer protection and control RET615, Transformer protection and control RET620 and Transformer protection and control RET630  
 —  
 02 Multiapplication Protection and Control REX640

For more information, please refer to the following documentation:

- Transformer Protection and Control RET615 Product Guide
- Voltage Protection and Control REU615 Product Guide
- Transformer Protection and Control RET620 Product Guide
- Transformer Protection and Control RET630 Product Guide
- Multiapplication Protection and Control REX640 Product Guide



—  
 01



—  
 02

# Distribution automation

## Motor protection

Motor protection is generally expected to provide overcurrent, unbalance, earth-fault and shortcircuit protection of the motor. However, the fundamental issue for motors is thermal protection, as overheating is the worst threat.

Motors need to be protected not only against electrical faults, but also against any improper usage. ABB's solutions focus on advanced thermal protection that prevents improper use. Overload conditions of short duration mainly occur during start-up. Improper use of running motors does not necessarily damage the equipment, but shortens its life span. Therefore, a reliable and versatile motor protection system not only protects the motor - it also prolongs its life cycle, which contributes to improving the return of investment of your motor drive.

## Product offering

The recommended products for motor protection are part of ABB's Relion® product family. The Relion product family offers the widest range of products for the protection, control, measurement and supervision of power systems for IEC and ANSI applications.

## Relion 605 series

The Relion 605 series offers a compact solution for the protection of medium-voltage and lowvoltage asynchronous motors in the manufacturing and process industry. The relays offer preconfigured functionality, which facilitates easy and fast commissioning of the switchgear. The relay can be used with both circuit-breaker and contactor-controlled motor drives.

## Relion 611 series

The Relion 611 series offers a pre-configured solution for power distribution in utility and industrial applications. This series is a suitable choice for protection and control of small asynchronous motors/drives. The protection relays are delivered pre-configured for easier and faster relay engineering and shorter time-to-operation.

## Relion 615 series

The Relion 615 series offers a compact and versatile solution for power distribution in utility and industrial applications. The series is a suitable choice for protection and control of asynchronous motors. Each protection relay is delivered with standard configuration, for easier and faster relay engineering and shorter time-to-operation.

## Relion 620 series

The Relion 620 series offers flexibility and performance for demanding power distribution in utility and industrial applications. Compared to the 615 series, the 620 series offers wider application coverage in one product, which enables wider standardization of the product type in your application. The protection relay is delivered with an example configuration, which can be pre-adapted to your specific requirements.

## Relion 630 series

The Relion 630 series protection relays feature flexible and scalable functionality to adapt to different needs in power distribution networks and industrial applications. The relays contain pre-configured application configurations, which can be tailored to meet specific requirements for also the most demanding distribution applications. In one easily scalable hardware solution, it includes extensive motor protection including differential protection function.

## Relion 640

The fully modular design allows customization and modification flexibility, and easy adaptation to changing protection requirements. For motor protection the base functionality in REX640 can be enhanced with motor application packages. The packages support both synchronous and asynchronous motors.

Please see dedicated chapter on page 64.

—  
01 Basic range: Motor protection and control REM601

—  
02 Medium range: Motor protection and control REM611, Motor protection and control REM615

—  
03 High range: Motor protection and control REM620, Motor protection and control REM630

—  
04 Multiapplication Protection and Control REX640

For more information, please refer to the following documentation:

- Motor Protection and Control REM611 Product Guide
- Motor Protection and Control REM615 Product Guide
- Motor Protection and Control REM620 Product Guide
- Motor Protection and Control REM630 Product Guide
- Multiapplication Protection and Control REX640 Product Guide



—  
01



—  
02



—  
03



—  
04

# Distribution automation

## Generator protection

Generators or generating units constitute one of the most crucial parts in a power system, making it essential to use a proper protection scheme. A generator has more failure modes than any other component in the power system. It is very important that the protection system detects all faults and that it does so quickly, as they may cause injury to personnel and damage to the equipment.

It is common practice that earth faults, short circuits and other severe faults must be detected by two independent protection devices. The fault must be cleared, even if one switching device fails to operate. The generator protection system must also provide adequate backup protection for the adjacent components.

A synchronous machine is a complex device, which can operate as a generator or as a motor. The armature/stator winding is arranged in three symmetrical phase belts in slots in the stator surface. The magnetic field intensity can be controlled via the DC-current in the rotor/field winding.

The protection of synchronous generators involves the consideration of more possible faults and abnormal conditions than the protection of any other power system component. We have to consider stator faults, rotor faults, abnormal operating conditions and faults in the connected power grid.

Today there are many and varying power station configurations. This makes the use of a uniform and standardized generator protection system very challenging. Besides the varying power station configuration, the following factors influence the design of the generator protection system:

- generator circuit-breaker or not
- earthing of the generator neutral
- location of the voltage transformers
- location of the current transformers

A rotating machine provides a classic application for differential protection. The generator

differential protection gives a fast and absolutely selective detection of generator stator short circuits.

## Product offering

The recommended products for generator protection are part of ABB's Relion® product family. The Relion product family offers the widest range of products for the protection, control, measurement and supervision of power systems for IEC and ANSI applications.

### Relion 615 series

The Relion 615 series offers a compact and versatile solution for power distribution in utility and industrial applications. The protection relays are delivered with a standard configuration for easier and faster relay engineering and shorter time-to-operation.

The series offers extensive interconnection and compact generator protection for both the generator and the prime mover in various small and medium-sized power plants.

### Relion 630 series

The Relion 630 series protection relays feature flexible and scalable functionality to adapt to different needs in power distribution networks and industrial applications. The relays contain preconfigured application configurations, which can be tailored to meet specific requirements for also the most demanding distribution applications. In one easily scalable hardware solution, it includes extensive protection for generator and generator-transformer units used in various power plants.

### Relion 640

The fully modular design allows customization and modification flexibility, and easy adaptation to changing protection requirements. In addition to conventional protection, control, measurement and supervision duties REX640 can also perform both generator and non-generator circuit breaker synchronizing. REX640 includes extensive protection for generator and generator-transformer units used in various power plants.

—  
01 Generator protection  
and control REG615,  
Generator protection  
andn control REG630  
—

02 Multiapplication  
Protection and Control  
REX640

Please see dedicated chapter on page 64.

For more information, please refer to the  
following documentation:

- Generator and interconnection protection  
REG615 Product Guide

- Generator Protection and Control REG630  
Product Guide
- Multiapplication Protection and Control REX640  
Product Guide



—  
01



—  
02



# Distribution automation

## Voltage protection

Overvoltage in a network occurs either due to the transient surges in the network or due to prolonged power frequency overvoltages. The overvoltage function can be applied to power network elements, such as generators, transformers, motors, busbar and power lines, to protect the system from excessive voltages that could damage the insulation and cause insulation breakdown.

Undervoltage and low voltage conditions are caused by abnormal operation or a fault in the power system. The undervoltage protection function is used to disconnect from the network devices, for example electric motors, which are damaged when subjected to service under low voltage conditions.

Additionally synchro-check function duration mode checks that the voltages on both sides of the circuit breaker are perfectly synchronized. It is used to perform a controlled reconnection of two systems, which are divided after islanding. It is also used to perform a controlled reconnection of the system after reclosing.

The frequency protection function uses positive phase sequence voltage to measure the frequency reliably and accurately. The system frequency stability is one of the main principles in distribution and transmission network maintenance. To protect all frequency-sensitive electrical apparatus in the network, operation above/below the allowed bandwidth for a safe operation should be prevented. To guarantee network frequency stability you need to apply underfrequency, overfrequency or load-shedding schemes.

Another important and common way of regulating the voltage in the power network is using a voltage regulator on the power transformer.

## Product offering

The recommended products for voltage protection are part of ABB's Relion® product family. The Relion product family offers the widest range of products

for the protection, control, measurement and supervision of power systems for IEC and ANSI applications.

## Relion 611 series

The Relion 611 series offers a pre-configured solution for power distribution in utility and industrial applications. The REU611 is designed for overvoltage and undervoltage protection and additional 2-stage frequency protection. The protection relays are delivered pre-configured for easier and faster relay engineering and shorter time-to-operation.

## Relion 615 series

The Relion 615 series offers a compact and versatile solution for power distribution in utility and industrial applications. The series is a suitable choice for protection and control of voltage based protection. REU615 standard configuration A is the ideal choice for voltage and frequency based protection, including synchrocheck and load-shedding functionality.

REU615 standard configuration B offers a dedicated relay with an automatic voltage regulator function for power transformers with on-load tap changer. Each protection relay is delivered with standard configuration, for easier and faster relay engineering and shorter time-to-operation.

## Relion 620 series

The Relion 620 series offers flexibility and performance for demanding power distribution in utility and industrial applications. Compared to the 615 series, RET620 offers wider application coverage in one product, including voltage and frequency based protection with automatic voltage regulator function. The relays are delivered with an example configuration, which can be pre-adapted to user requirements.

## Relion 630 series

The Relion 630 series protection relays feature flexible and scalable functionality to adapt to different needs in power distribution networks and industrial applications. The relays contain pre-configured application configurations, which can be tailored to meet specific requirements for also

the most demanding distribution applications. In one easily scalable hardware solution, you gain load-shedding with automatic voltage regulator functions.

### Relion 640

The fully modular design allows customization and modification flexibility, and easy adaptation to changing protection requirements. The base package includes most of the standard protection functions needed for voltage protection. Please see dedicated chapter on page 64.

For more information, please refer to the following documentation:

- Voltage Protection and Control REU611 Product Guide
- Voltage Protection and Control REU615 Product Guide
- Transformer Protection and Control RET620 Product Guide
- Transformer Protection and Control RET630 Product Guide
- Multiapplication Protection and Control REX640 Product Guide



01



02



03

# Distribution automation

## Capacitor bank protection

Capacitors form an essential part of the network and must be properly protected against overloads, overcurrents or other distortion during their connection to the network.

Capacitor banks are used for reactive power compensation in utility substations and industrial power systems. Most of the loads connected to the distribution feeders have the power factor on the inductive side, for example, motors and arc furnaces. This reactive current component does not contribute the conversion into useful power, but it stresses the network components, introducing additional voltage drops and heat losses. The most favorable approach is to compensate the reactive current as close to the consumption as possible. The compensation can be done locally, at the place where it is needed, for example, at the factory or facility. It can also be done remotely by, for example, a utility organization.

Extra charges are always applied when excess level of reactive load is taken from the network. Therefore, the utilities have to evaluate the reactive power balance within their distribution network and do the necessary compensation at the most suitable location.

## Product offering

The recommended products for capacitor bank protection are part of ABB's Relion® product family. The Relion product family offers the widest range of products for the protection, control, measurement and supervision of power systems for IEC and ANSI applications.

## Relion 615 series

The Relion 615 series offers a compact and versatile solution for power distribution in utility and industrial applications. The series is a suitable choice for protection and control of capacitor banks. Additionally, it can be applied to harmonic filter protection. Each protection relay is delivered with a standard configuration, for easier and faster relay engineering and shorter time-to-operation.

## Relion 640

The fully modular design allows customization and modification flexibility, and easy adaptation to changing protection requirements. The base functionality in REX640 can be enhanced with a special application package for shunt capacitor protection.

Please see dedicated chapter on page 64.

For more information, please refer to the following documentation:

- Capacitor Bank Protection and Control REV615 Product Guide
- Multiapplication Protection and Control REX640 Product Guide

### Busbar protection

The last, but not least, part in electrical power systems is defined by the busbar application. The busbar is an aluminum or copper conductor supported by insulators that interconnects the loads and the sources of electric power. For example, in metal enclosed switchgear, it is represented by copper bars in the busbar compartment. The requirements for busbar protection in respect of immunity to maloperation are very high. For busbar protection it is essential to employ a differential protection principle.

### Product offering

The recommended products for busbar protection are part of ABB's Relion® product family. The Relion product family offers the widest range of products for the protection, control, measurement and supervision of power systems for IEC and ANSI applications.

### Relion 611 series

The Relion 611 series offers a pre-configured solution for power distribution in utility and industrial applications. It is a suitable choice for high-impedance busbar protection. The protection relays are delivered pre-configured for easier and faster relay engineering and shorter time-to-operation

### Relion 640

The fully modular design allows customization and modification flexibility, and easy adaptation to changing protection requirements. The base functionality in REX640 can be enhanced with a special application package for busbar highimpedance protection. Please see dedicated chapter on page 64.

For more information, please refer to the following documentation:

- Busbar Protection and Control REB611 Product Guide
- Multiapplication Protection and Control REX640 Product Guide.



01



02



03

# Distribution automation

## Protection and control REX640

REX640 makes protecting all your assets in advanced power generation and distribution applications easy. The fully modular design allows unequalled customization and modification flexibility, and easy adaptation to changing protection requirements throughout the relay life cycle. This is asset management at its best.

## Complete application coverage with one device for optimal cost-effectiveness

REX640 is the outcome of a long-standing evolution, building on ABB's strong heritage of freely configurable multifunctional relays. The ability to cover the full range of utility and industrial applications and manage multiple applications simultaneously, with the same device, guarantees flexible, versatile and cost-efficient protection solutions.

REX640 has been designed to support the increasing digitalization of substations. REX640 thereby supports a variety of digital switchgear solutions and is suitable for both single and double-busbar applications. REX640 offers as many as 20 current and voltage measurement channels in total, supporting both conventional instrument transformers and sensors, not to mention the ability to receive four streams of sampled measured values (SMV) via IEC 61850-9-2 LE-based process bus communication. As the newest member of ABB's Relion® protection and control family of relays, REX640 further reinforces Relion's position as the range of relays to rely on.

## New application package concept for maximum convenience and flexibility

REX640 introduces an entirely new application package concept, by offering a variety of readymade application packages to choose from. The application packages include various protection and control functions, which can be flexibly combined to create protection solutions that meet your unique protection requirements.

The available packages support the following applications:

- Feeder protection
  - Line differential protection
  - Line distance protection
  - Interconnection protection
  - Fault locator
- Power transformer protection
  - Two and three-winding differential protection
  - On-load tap-changer control
- Machine protection
  - Asynchronous machines
  - Synchronous machines
- Shunt capacitor protection
- Busbar protection
- Automatic synchronization
  - Generator circuit breaker
  - Non-generator circuit breaker
- Petersen coil control
- Arc protection with supervised sensors
  - Loop and lens-type sensors

## Fully modular hardware and software for maximum flexibility for the entire relay lifetime

The modularity and scalability of both software and hardware allow you to create your own, unique relay for your specific protection requirements. The ready-made application packages make ordering your relay smooth and easy.

When requirements change, so will REX640. Adapting to changing protection requirements is flexible and easy – the software and hardware can be modified anytime. In addition, new software and hardware developments will be continuously and easily accessible – throughout the relay's entire life cycle.

## Intuitive human-machine interface for enhanced user experience

A novel, application-driven approach to the local human-machine interface (LHMI) allows support for entirely new applications. The unique, 7-inch color touch screen visualizes power distribution process information in an entirely new way. This results in increased situational awareness and maximum usability.

—  
01 Protection and control  
REX640

—  
02 Phasor diagram of  
a three winding power  
transformer on the LHMI

—  
03 New application  
package concept

Ready-made application-based pages minimize the need for graphical engineering, which saves both time and efforts. The LHMI pages can also be customized, if necessary, for optimum freedom.

**REX640 – innovative, flexible and easy to use**

- Complete application coverage with one device for optimal flexibility and cost-effectiveness
- Ready-made application packages for convenient and smooth ordering
- Customization freedom with modular and scalable design

- Fully modular hardware and software for maximum flexibility throughout the entire relay life cycle
- Easy adaption to changing protection requirements
- Continuous access to the latest software and hardware developments
- Ready-made application-based LHMI pages – saving both time and efforts
- Increased situational awareness and optimal usability with application-driven LHMI
- Designed to support the increasing digitalization of substations

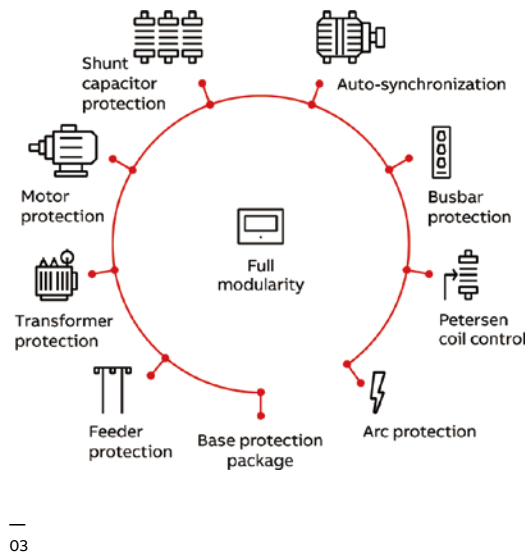
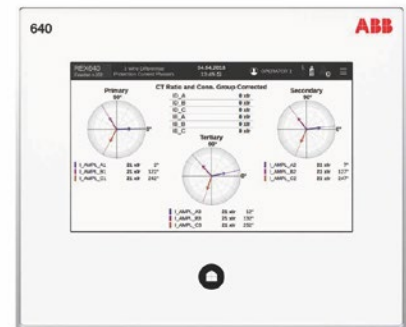

# Distribution automation

—  
01 Arc fault damage as a function of the arc fault energy and the arc fault impact time

## Arc fault protection

An electric arc short-circuit in a switchgear installation is normally caused by a foreign object entering the cubicle or by component failure. The arc causes an explosion-like heat and pressure effect, usually causing vast damage to the switchgear and in the worst-case scenario also injury to the operating personnel.

An adequate arc protection system protects your substation against arc faults via minimizing the burning time of the arc, thus preventing excessive heat and damage. It minimizes material damage and allows power distribution to be smoothly and safely restored. The system can also bring cost benefits even before an arc fault occurs. As older switchgear is more prone to arc faults, an arc protection system will effectively extend the life of your switchgear enhancing the return on your investment.

Sources of arcing may be insulation faults, maloperating devices, defective bus or cable joints, overvoltage, corrosion, pollution, moisture, ferroresonance (instrument transformers) and even ageing due to electrical stress. Most of these arc fault sources could be prevented by sufficient maintenance. However, regardless of precautions taken, human errors can lead to arc faults.

Time is critical when it comes to detecting and minimizing the effects of an electric arc. An arc fault lasting 500 ms may cause severe damage to the installation. If the burning time of the arc is less than 100 ms the damage is often limited,

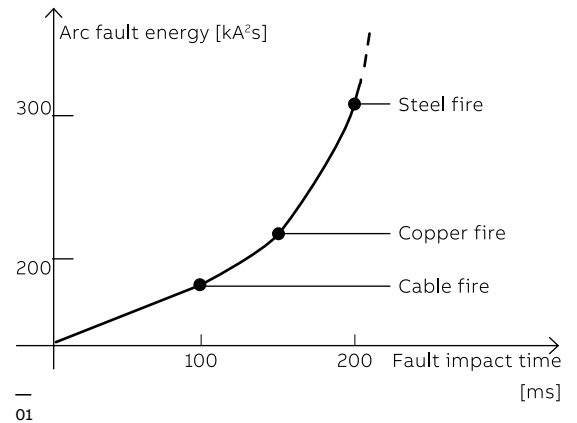

but if the arc is extinguished in less than 35 ms its effect is almost unnoticeable.

Generally applied protection relays are not fast enough to ensure safe fault clearance times at arc faults. The operation time of the overcurrent relay controlling the incoming circuit breaker may, for instance, have been delayed to hundreds of milliseconds for selectivity reasons. This delay can be avoided by installing an arc protection system. The total fault clearance time can be reduced to a maximum of 2.5 ms plus the circuit breaker's contact travel time. Further, when a cable compartment fault occurs, auto-reclosing can be eliminated by employing arc fault protection.

—  
02 The REA system is a fast and flexible arc fault protection system for air-insulated low voltage and medium - voltage switchgear.

### Product offering

The recommended products for arc fault protection is the arc fault protection system REA 101 with its extension units REA 103, REA 105 and REA 107 and protection and control relays from ABB's Relion® product family.

### REA system

The REA system is a fast and flexible arc fault protection system for switchgears. This type of fast and selective arc fault protection system is a natural constituent of modern switchgear panels, and a safety and security investment for older switchgear panels, to protect human lives and prevent or reduce material damage. The REA system can be described as the fastest operating arc fault protection system in ABB's product portfolio, with trip command time in less than 2.5 ms.

### Relion 615 series and 620 series

The Relion® product family offers integrated arc fault protection in its widest range of products for the protection, control, measurement and supervision of power systems for IEC and ANSI applications.

The Relion 615 and 620 series offer integrated three channel arc fault protection – to protect human lives and prevent or reduce material damage of protected switchgear – for power distribution in utility and industrial applications. The arc fault protection function operates with high-speed outputs with operation times down to 4 ms.

### Relion 640

REX640 protection relays are equipped with arc flash sensor card, that supports either loop or lens sensors or a combination thereof, and includes supervision of the sensors . By using suitable sensor combinations for different bays, a selective arc flash protection scheme can be build up for the complete switchgear.

For more information, please refer to the following documentation:

- Arc Fault Protection REA 101 main module Product Guide
- Arc Fault Protection REA 103 extension module Product Guide
- Arc Fault Protection REA 105 extension module Product Guide
- Arc Fault Protection REA 107 extension module Product Guide
- Feeder Protection and Control REF615 Product Guide
- Motor Protection and Control REM615 Product Guide
- Transformer Protection and Control RET615 Product Guide
- Voltage Protection and Control REU615 Product Guide
- Capacitor Bank Protection and Control REV615 Product Guide
- Feeder Protection and Control REF620 Product Guide
- Motor protection and control REM620 Product Guide
- Transformer Protection and Control RET620 Product Guide
- Multiapplication Protection and Control REX640 Product Guide



# Distribution automation

— Smart Substation Control and Protection SSC600

— Substation Merging Unit SMU615

— 01 Example of centralized protection and control

## Centralized protection and control

Advances in communication systems, including time synchronization, their integration to substation applications and the standardization of protocols have facilitated the operation and the diagnosis of failures in complex grids and have enabled new possibilities for protection and control schemes. These advances have opened space for the implementation of the centralized protection and control system.

The centralized protection and control concept is based on the concentration of substation protection and control in a single device and the utilization of communication networks to converse between different components, bays, substations and the related operators. The most substantial protection philosophy change in the system is the total or partial shift of functions from the bay level, i.e., from the relays, to the station level in the substation.

## Product offering

ABB Ability™ Smart Substation Control and Protection for electrical systems SSC600 is a smart substation device designed for protection, control, measurement and supervision of utility substations and industrial switchgear and equipment. The design of the device has been guided by the IEC 61850 standard for communication and interoperability of substation automation devices. It is fully integrable with Relion series IEDs for creating a complete solution. Optional functionality is available at the time of order for both software and hardware, for example, special application packages and additional communication modules.

Depending on the chosen product options, the device is adapted for:

- Protection for overhead line and cable feeder in isolated neutral, resistance earthed, compensated and solidly earthed networks.
- Protection, control, measurement and supervision of asynchronous motors in manufacturing and process industry.
- Transformer protection and control for power transformers, unit and step-up transformers including power generator-transformer blocks in utility and industry power distribution systems.

## Substation Merging Unit SMU615

SMU615 is a dedicated substation merging unit intended for measuring current and voltage signals from the instrument transformers and merging them into the standard digital output format that other devices can further use for various power system protection application purposes. SMU615 itself includes no protection functionality but it offers the physical interface into the switchgear primary equipment, that is, circuit breaker, disconnect and earthing switch. SMU615 is a member of ABB's Relion® product family and is characterized by the compactness, simplicity and withdrawable-unit design.

For more information, please refer to the following documentation:

- Smart Substation Control and Protection SSC600 Product Guide
- Substation Merging Unit SMU615 Product Guide



01



02

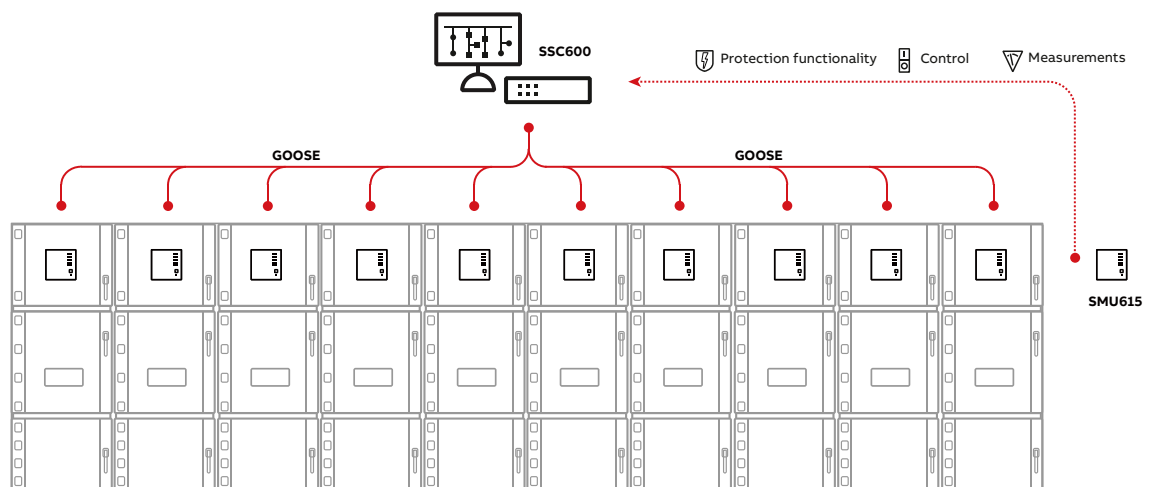

03

# Distribution automation

—  
01 Substation  
Management Unit  
COM600S

## Substation automation

ABB's protection and control relays are an integral part of substation automation systems. The substation automation system, together with the protection relays, lay the foundation for all the higher-level remote functions, such as advanced power system management and the monitoring of the condition of the equipment, when it is in service. Substation-level systems are easy to use and to adapt to customer-specific requirements.

Increased competition is driving many power providers to focus on system productivity, with the aim to reduce costs and increase customer satisfaction. To reach this goal, an upgrade of an aging infrastructure is usually involved. Updating to substation automation offers the opportunity to reduce operational and maintenance costs, increase plant productivity with the help of enhanced schemes, as well as condition monitoring for the apparatus (e.g., circuit breakers, power transformers).

## Product offering

The COM600 series offers versatile substation management units. These units are deployed together with protection and control relays and other communication devices to realize smart substation and grid automation solutions in utility and industrial distribution networks. The COM600 series units perform the combined role of a user interface, a communication gateway and an automation platform in a single physical unit.

The COM600 series accommodates web technology-based functionality, which provides access to substation devices and processes via a web browser-based human machine interface (HMI). All standard substation monitoring and control aspects can be handled using the web-HMI.

The COM600 series integrates substation devices, like protection and control relays, substation controllers and meters, based on the IEC 61850 communication standard, as well as most other commonly used communication standards and legacy protocols. Seamless connectivity can be established with gateway functionality between the substation devices

and external higher-level systems such as the Network Control Center (NCC) or a process such as the Distributed Control System (DCS) using IEC 60870-5, DNP3, Modbus or OPC-based protocols.

The COM600 series hardware platform is based on ruggedized mechanics with no moving parts subject to wear and tear. The compact and robust design is well adapted to harsh environments.

The COM600 series comprises of two products:

- COM600S for Substation Automation (for IEC and ANSI markets)
- COM600F for Feeder Automation (for ANSI markets only)

The COM600S has the capability to function as a combined substation HMI, gateway and process controller in a small to medium-sized substation automation installation. Its HMI feature enables substation monitoring and operations. It integrates various units to provide access to realtime data. It also records process data in its historian to enable access to past data. Its logic processor enables implementation of substationlevel automation tasks. The gateway functionality provides a provision to communicate data from protection and control relays in the substation and COM600S itself to higher-level systems and vice versa.

For more information, please refer to the following documentation:

- COM600S Substation Management Unit Product Guide



—  
01

—  
02 Remote I/O unit  
RIO600

### Remote I/O concept

ABB's remote I/O concept introduces a new way of extending the I/O capabilities of protection relays. The concept is aimed at increasing the hardware functionality of the protection relays, while still maintaining the relay's compact design. This way remote I/O can be used, when it is needed. The information between the remote I/O units and the main protection relay is exchanged over the latest communication standard IEC 61850. This enables easy integration into the systems and is in line with the latest standards.

The remote I/O concept also benefits from installing the I/O units as close as possible to the place where the signals need to be digitalized, thus limiting extensive wiring within the switchgear, substation or plant. Digitalization of the signals allows users to use information wherever needed, without the need of installing additional auxiliary relays or terminals. IEC 61850 enables signals supervision, thus faster recognition of any errors and proactive operation, if these conditions happen during a critical process.



—  
02

### Product offering

The remote I/O unit RIO600 is designed to expand the digital and analog I/O of ABB's Relion® series protection relays and to provide I/O for the COM600 series devices using IEC 61850 communication.

RIO600 is designed using a modular architecture where the amount and type of I/O ports can be added through modules. The RIO600 modules can be stacked on a standard DIN rail to achieve the required configuration.

RIO600 is built on an industrial hardware platform, which provides the same reliability, performance and real-time functionality as ABB's protection relays, withstanding extreme temperatures, electromagnetic interference and stringent industry standards.

RIO600 provides an additional I/O within the switchgear itself by using the Ethernet-based IEC 61850 horizontal GOOSE communication. The signals can be transmitted within the switchgear and to the automation systems. Similarly, signals from the automation systems can be executed through RIO600 connected to numerical protection relays.

For more information, please refer to the following documentation:

- Remote I/O unit RIO600 Product Guide









# Distribution automation

## Compact power management

Power management systems (PMS) are essential for a safe, efficient and reliable operation of a power system within an electrical network. The PMS functionality includes load-shedding generator control, power sharing, network synchronization and power restoration. PMS solutions protect and optimize the stability of industrial systems against disturbances by ensuring power sharing between generators, when the industrial power system is islanded from the grid. These solutions also ensure that the generators meet the required power demand, when the network is grid-connected.

PMS solutions are suitable for industrial power networks:

- With captive power generation, islanded or grid-connected
- With substantial and critical loads
- With unstable grid connectivity
- Without grid connectivity

The PMS functionality suite is applicable to various industrial segments, for example, oil and gas, marine, pulp and paper, metals, minerals and building automation.

Load-shedding is required, when the electrical load demand exceeds the capacity of the available power sources, subsequent to the loss of power sources or network dis-integration. The load-shedding system has to ensure availability of electrical power to all essential and, most importantly, critical loads in the plant. This is achieved by switching off the nonessential loads in case of a lack of power in the electrical network or in parts of it (subnetwork or island). The loadshedding functionality can also be deployed in industrial power networks with sole dependency on the utility networks. The lack of electrical power can be caused by a loss of generation capacity or power grid connectivity or the tie line feeding power to the plant.

Based on the shortfall of available power in the power network, the load-shedding action initiated by the system ensures that only identified loads are shed, the system is stable

after load-shedding, and the impact on the associated plant operation is minimal. The system allows flexibility to select or deselect the load feeders to be load-shed at any point in time during plant operation.

The load-shedding function must be accurate and selective. It is important that it operates only when necessary.

## Load-shedding principles

There are two load-shedding system principles: (1) reactive load-shedding (reacts on measurement) and (2) active load-shedding (reacts on cause).

Reactive load-shedding is most commonly used in utility networks in primary distribution substations. Reactive load-shedding reacts based on measuring the system frequency and/or voltage. The system as such can contain several triggering levels for these values. Each triggering level corresponds to one of the load-shedding priority classes or steps, for example, activation of the first triggering level, which sheds the loads belonging to priority class 1. Typically two or three priority classes or steps are used. Restoration of the shed feeders can take place manually or automatically, in a pre-programmed scenario. Selectivity against protection functions has to be secured, for example, the load-shedding system has to have a change to operate before the protection system is initiated.

Active load-shedding is mostly used in industrial distribution networks. Active load-shedding reacts based on measuring power, current values on supply and load feeders (key feeders included). The load-shedding system knows the present loading situation and calculates shedding priorities for different network scenarios, such as tripping or overloading of a generator or a network power source. Knowing the individual loads of feeders, only the necessary amount of load (feeders) will be shed. The reactive loadshedding system can work as a back-up for active load-shedding.

—  
01 Load-shedding  
controller PML630

### Product offering

ABB's Relion® protection relays are characterized by functional scalability and flexible configurability to perform reactive and active load-shedding.

PML630 is a power management relay that provides a comprehensive load-shedding solution for the power network in an industrial plant. It protects the plant against blackouts and power source outages due to system disturbances. This relay is a member of ABB's Relion product family and a part of its 630 series.

PML630 complies with IEC 61850 and offers seamless connectivity with Relion family protection relays, RIO600 I/O and COM600S units to realize the load-shedding functionality. The protection relays use GOOSE and MMS communication profiles for I/O data exchange with other Relion family protection relays and COM600S.

PML630 provides system level protection to small or medium-sized industrial systems from the system disturbances. PML630 supports different modes of load-shedding functions:

- Fast load-shedding (active load-shedding)
- Slow (overload or maximum demand violationbased) load-shedding (active load-shedding)
- Manual load-shedding (reactive load-shedding)
- Underfrequency load-shedding as a backup to fast and slow load-shedding (reactive loadshedding)

A network power deficit occurs when a power source such as a generator or a grid transformer trips. There could also be a power shortage, when a network becomes isolated due to trip of a bus coupler or a bus tie breaker. All load-shedding functions can be active concurrently.

For more information, please refer to the following:

- Load-shedding controller PML630 Product Guide
- Distribution automation solutions web page (<http://new.abb.com/medium-voltage/distribution-automation/distributionautomation-solutions>)

### Solution offering

The Compact Power Management System (cPMS) is a load-shedding power management solution built on Relion PML630, Substation Management Unit COM600S, Remote I/O unit RIO600 and the Relion 615, 620 or 630 series feeder relays.

### Relion Interactive Selection Guide

The Relion Interactive Selection Guide (ISG) helps you select the protection relay type that is the most suitable for your application. It also provides links to relevant documentation online. The Relion ISG is available at <http://abb.relionisg.com>



—  
01

# Distribution automation

—  
01 C Single line diagram (SLD) of medium voltage switchgear architecture applied, suitable for carrying out automatic and manual transfer (ATS).

## Automatic transfer systems

Automatic transfer systems (ATS) are used to ensure maximum service continuity, supplying the power users uninterruptedly. All this is possible using various systems based on different kinds of techniques. The most common of these are outlined below, with the relevant average transfer times:

Delayed:	1500 ms
Depending on the residual voltage:	400-1200 ms
Synchronized ATS:	200-500 ms
High speed transfer device:	100 ms
High speed transfer system:	30 ms

The first two systems are the simplest and can also be achieved with conventional logics and instruments. They guarantee average transfer times and can therefore be used in installations where voltage gaps are not particularly critical. The other three systems: (1) synchronized automatic transfer system, (2) high speed transfer device and (3) high speed transfer system require microprocessor-based apparatus with high technology content. They guarantee fast transfer times. They are used in plants where the process is particularly critical, in which slow transfers would cause serious malfunction or interruption of the process itself.

ABB offers all types of transfer systems, from the simplest to the most complex.

## Synchronized automatic transfer system

Protection relays from Relion® product family can be used in medium-voltage switchgear to manage automatic and manual transfer between different incoming feeders. The time needed for automatic transfer carried out by means of the Relion family protection relays is between 200 to 300 ms (including the circuit breaker operating times). The time can vary within the range indicated in relation to the complexity of the software transfer logics.

Switchgear equipped with Relion protection relays, suitably configured, are complete and efficient systems able to manage transfer between one power supply system and an alternative one, or to reconfigure the network, passing from double radial distribution to a simple system, in a fully automatic way.

It is also possible to carry out the same operation manually from a remote control station, or from the front of the switchgear under user supervision. Manual transfer means making the passage parallel, by means of the synchronism control function (synchro-check) implemented from the protection relay, the power supply lines are closed simultaneously with synchronization of the voltage vectors to then return to being disconnected when the transfer has taken place. The applications described do not require additional instruments.

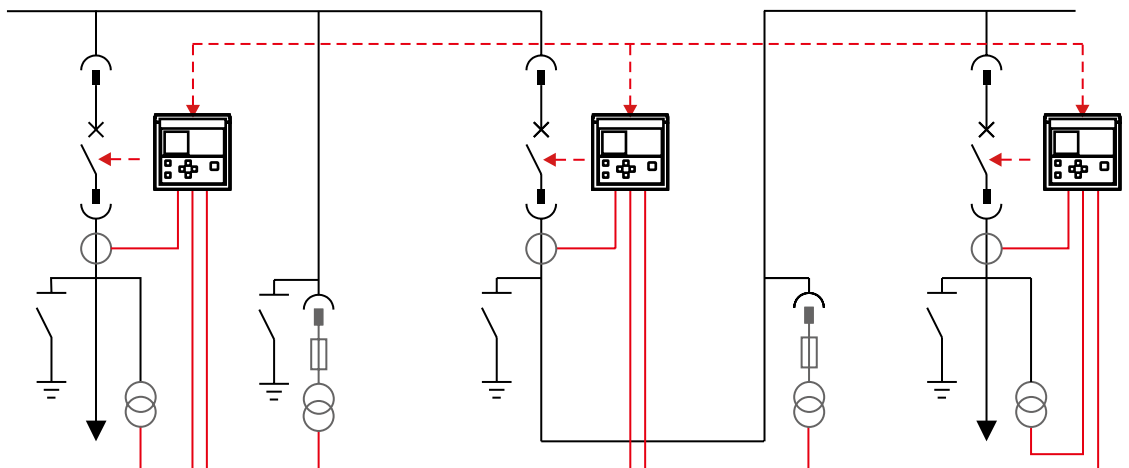

- 02 An example of a switchgear configuration
- 03 SUE 3000 High Speed Transfer Device

**SUE 3000 - High speed transfer device / High speed transfer system**

Voltage decrease or complete supply interruptions represent the most crucial and critical problems for the quality of energy supply today. The SUE 3000 High Speed Transfer Device guarantees an optimal safeguarding of energy supply. The device ensures, in combination with the existing circuit breakers, the continued power supply and protects the subsidiary process from expensive stoppage time. Further, the operation of the installation is considerably simplified through the possibility of manually-initiated transfers for targeted clearings.

To achieve the fastest possible transfer time of 30 ms the High Speed Transfer System has to be used. This system is a combination of the SUE 3000 device, special trigger devices and very fast magnetic circuit breakers.

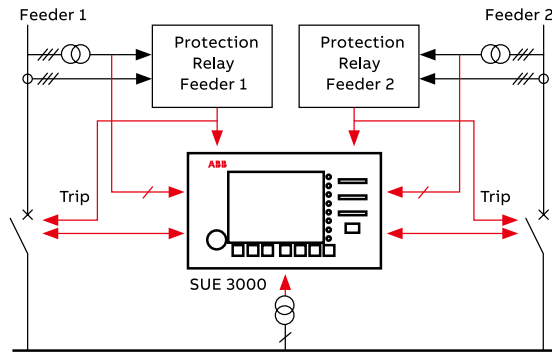

02

**Application areas**

The SUE 3000 High Speed Transfer Device can be used where ever a disturbance of the electrical supply would lead to a breakdown in production, which would have a significant impact on the operating costs.

Possible areas of utilization include:

- Auxiliary installations serving power stations
- Environmental technology installations
- Voltage supply to continuous industrial processes

To realize permanent availability, the load is supplied from at least two synchronized feeders, which are independent from one another and equipped with a SUE 3000 device.

SUE 3000 takes on the task of ensuring uninterrupted continuous operation of the connected devices in case of a power supply breakdown. The device takes different physical factors into account and executes the quickest possible transfer to a different feeder, which is kept on stand-by.

Corresponding to its multifaceted areas of application, the SUE 3000 is set up for different switchgear arrangements.

**Permanent network comparisons**

An exceptionally important characteristic, that clearly distinguishes SUE 3000 from competing concepts, is that synchronicity criteria are continuously available, as they are computed online. This is the reason that, in case of an initiation, the appropriate transfer mode is already determined and can be immediately initiated. This means that the probability of a fast transfer is considerably enhanced. Systems which wait for the instant of initiation to start the determination of the network status are not capable to perform a fast transfer with minimum interruption time.

**Transfer modes and times**

Four different transfer modes are available in detail: (1) fast transfer, (2) transfer at the 1st phase coincidence, (3) residual voltage transfer and (4) time-operated transfer. When a fault occurs, fast transfer is the optimal transfer mode for ensuring that only a minimum interruption of the voltage supply occurs. With fast transfer mode, the total transfer time, counting from a fault in the main feeder until the standby feeder is cut in, is less than 100 ms.

For more information, please refer to the following:

- High Speed Transfer Device SUE 3000 Product Description
- Distribution automation solutions web page (<http://new.abb.com/medium-voltage/distribution-automation/distribution-automation-solutions>)

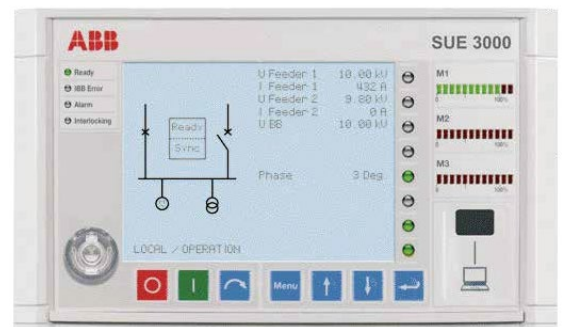

03

# Single-line diagrams

## Single-line diagram of typical units

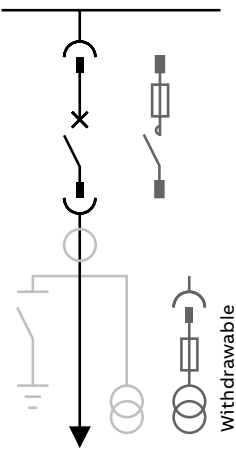

IF - Incoming/outgoing feeder

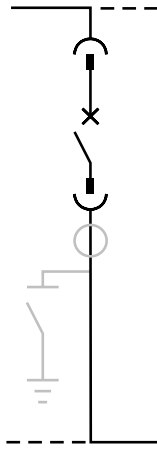

BT - Bus-tie

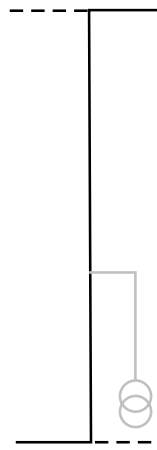

R - Riser

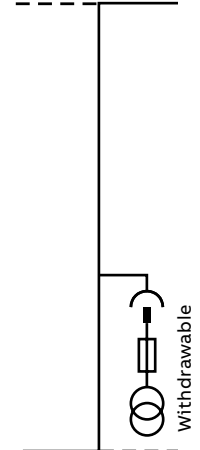

RM - Riser with measurements

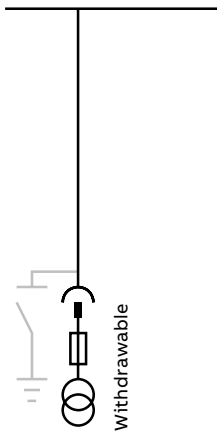

M - Measurements

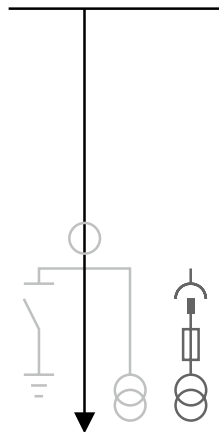

IFD - Direct incoming/outgoing feeder

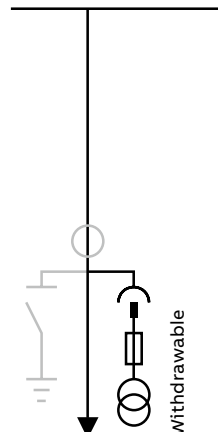

IFDM - Direct incoming/ outgoing feeder with measurements

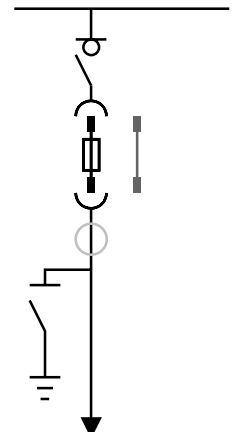

DF - Switch-disconnector unit

### Key to components

— Standard components

— Accessories

— Alternative solutions

**Single-line diagram of the busbar applications**

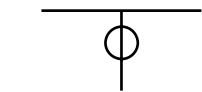

**Current transformers**

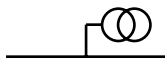

**Voltage transformers**

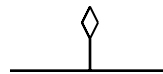

**Duct entry**

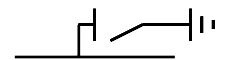

**Earthing switch**

**Graphical symbols**



**Circuit-breaker**



**Contactor**



**Switch-disconnector**

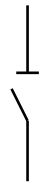

**Disconnecter**



**Isolating bar**



**Socket and plug**



**Voltage transformers**

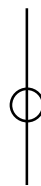

**Current transformers**



**Fuse**



**Earth**



**Cable entry**



**Busbar entry**



**Current sensor**

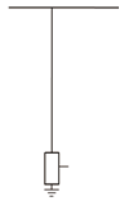

**Voltage sensor**

**Type: ...12 kV ...31.5 kA**

Depth (mm)	1310/1620		1310/1620/1810				1310/1620/1810			
Height (mm)	2200 <sup>(1)</sup>		2200 <sup>(1)</sup>				2200 <sup>(1)</sup>			
Height with gas exhaust duct (mm)	2675 <sup>(3)</sup>		2675 <sup>(3)</sup>				2675 <sup>(3)</sup>			
Width (mm)	500/650/800		800				1000			
Rated current (A)	630	1250	630	1250	1600	2000	630	1600	2000	2500
IF	● <sup>(1)</sup>	●			●	●				●
BT	●	●			●	●				●
R	●	●			●	●				●
RM	●	●			●	●				●
M	●		●				●			
IFD	●	●								
IFDM	●	●								

**Type: ...12 kV ...40 kA**

Depth (mm)	1310/1620/1810					1310/1620/1810				
Height (mm)	2200 <sup>(1)</sup>					2200 <sup>(1)</sup>				
Height with gas exhaust duct (mm)	2675 <sup>(3)</sup>					2675 <sup>(3)</sup>				
Width (mm)	800					1000				
Rated current (A)	630	1250	1600	2000	2500	630	1250	1600	2500	
IF		●	●	●					●	
BT		●	●	●					●	
R		●	●	●					●	
RM		●	●	●					●	
M	●					●				
IFD										
IFDM										

Note:  
 (1) The height of the unit is a function of the height of the low voltage compartment, available in the 705 and 1100 mm versions.  
 (2) For the characteristics of the unit equipped with contactor refer to page.  
 (3) Others solutions are available, please contact ABB representative.

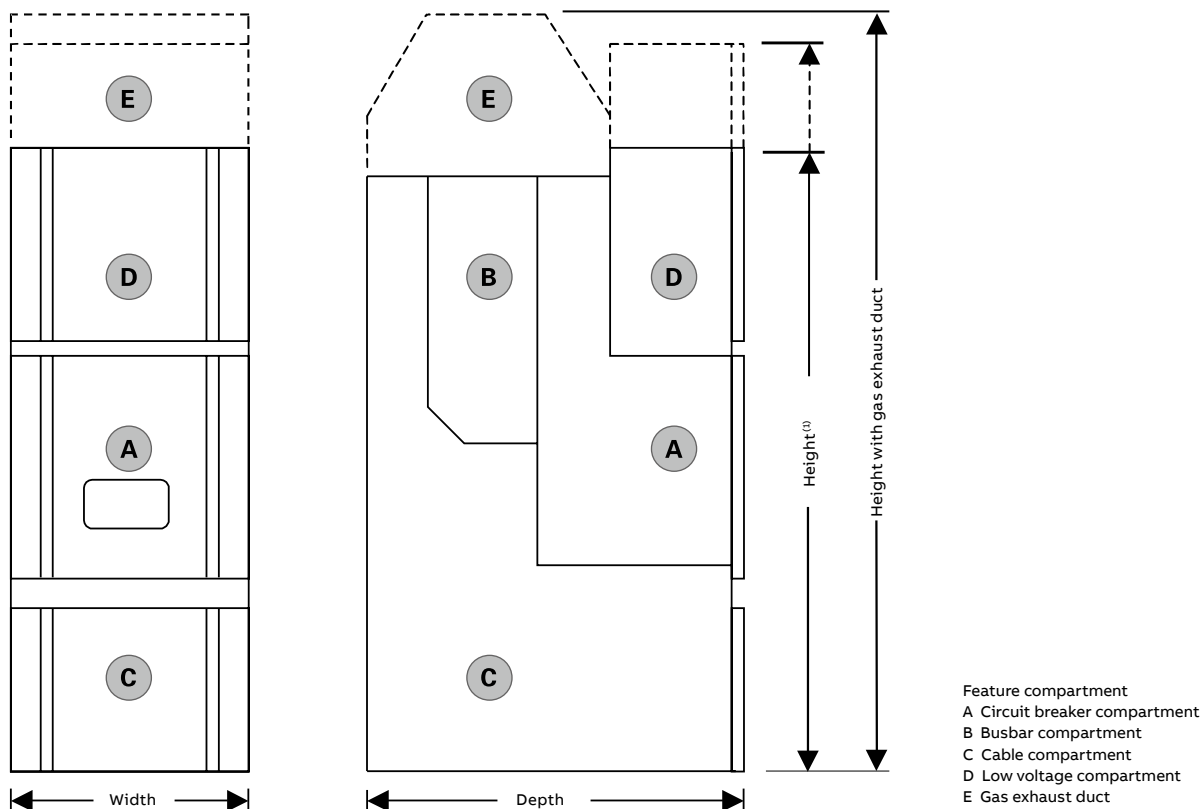

# Layout and Installation

## Primary scheme of distribution room

It is suggested that appropriate space should be reserved between the back cover plate of the switchgear and the wall, and between both sides of the switchgear and the wall as maintenance channels.

Figure 17.1 is a reference scheme of the plan layout of the distribution room. The scheme can be used as reference for installation by means of cables are led in the distribution room via a cable trench or led in downward or upward direction. In the figure, the switchgear cubicles are arranged in a single row. If the switchgear cubicles are to be arranged in two rows opposite to each other, the distance between the two rows shall be larger than or equal to 2,500 mm.

## Construction of installation base of switchgear

It is suggested that appropriate space should be reserved between the back cover plate of the switchgear and the wall, and between both sides of the switchgear and the wall as maintenance channels.

The construction of the installation base for the switchgear should conform to the regulations in relevant clauses in the Code of Erection and Acceptance of Electric Power Construction. Whichever incoming/outgoing way is adopted, pre-processed channel steel is recommended for the installation base of UniGear ZS1.

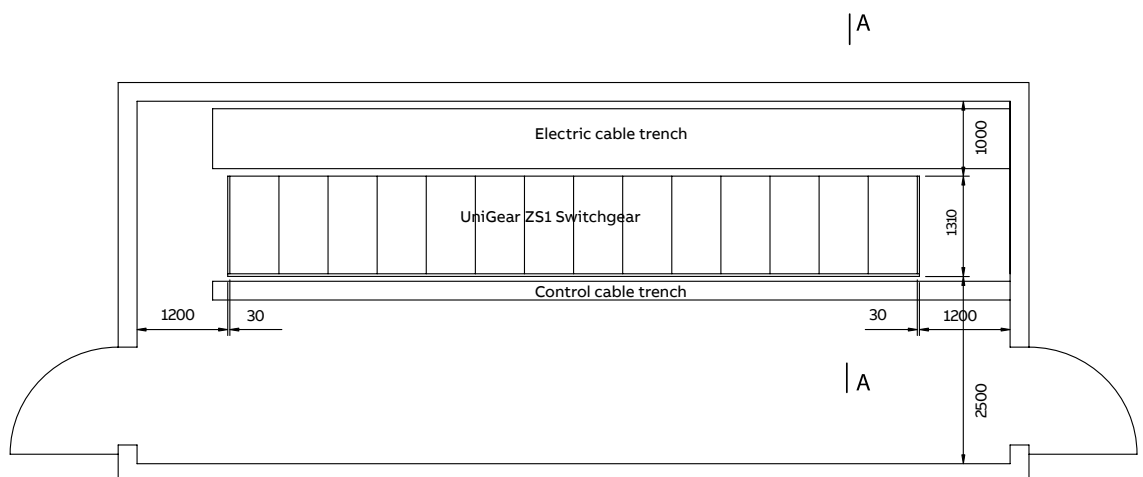

Figure 17.1 Primary scheme of distribution room

During civil design, the reserved height for the base frame should be taken into consideration for the foundation elevation of the switchgear (see attached figure 17.2), the margin should be remained. In addition, anchored steel plates should be embedded along the longitudinal direction of the frame on the switchgear foundation, with an interval of 1-1.5 m.

The base frame is welded by channel steel. The requirements on basic dimensions of the frame and the layout of the cable trench are shown in attached figures 17.3. The extended distance of the channel steel on the base frame should be consistent with the dimension of the switchgear

frame. The total length of the frame should be determined based on the layout of the switchgear cubicles and the number of switchgear cubicles in each row. Figure 17.4 is the manufacturing diagram of UniGear ZS1 base frame.

During embedding of the base frame, horizontal alignment should be conducted. The horizontal error and flatness error should not exceed 1 mm per m and the total error should not exceed 3 mm.

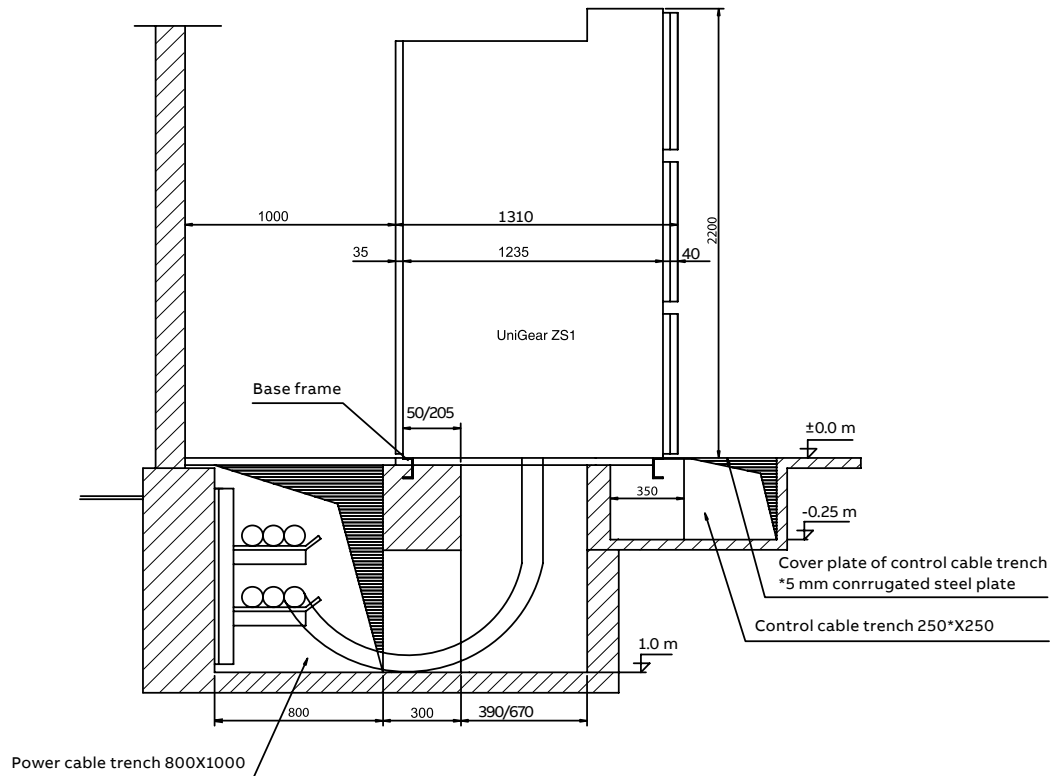

Figure 17.2: Typical plan layout of distribution room (A-A section view of figure 17.1)

**Installation of switchgear**

UniGear ZS1 should be installed in the distribution room which is dry, clean, and ventilated. Prior to installation, the base frame and floor should have been completed and passed the acceptance inspection, and the window and door decoration and indoor lighting and ventilation works should have been basically completed.

See the installation Manual for specific installation methods.

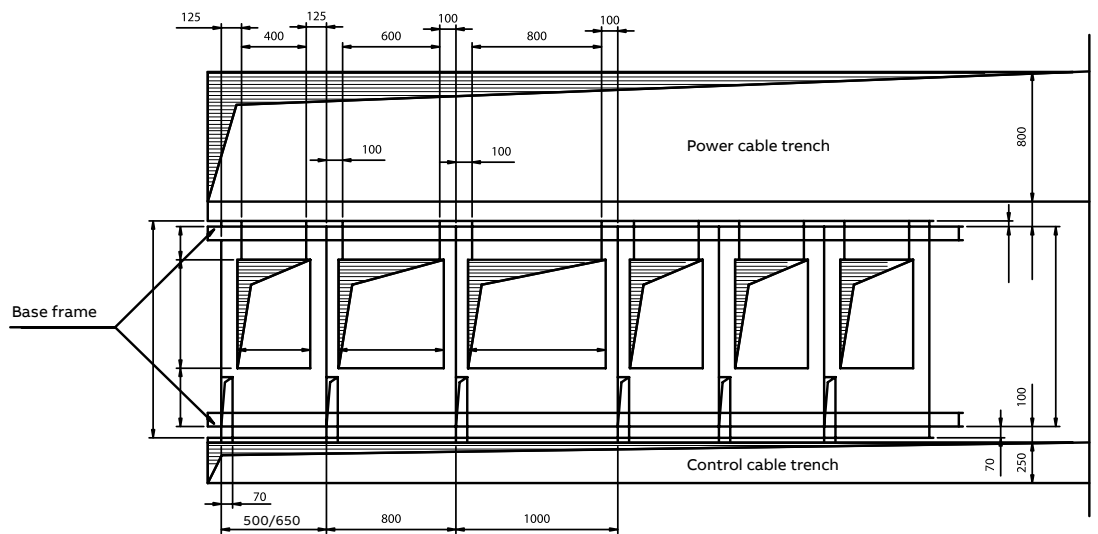

Figure 17.3 Typical layout of cable trenches of distribution rooms

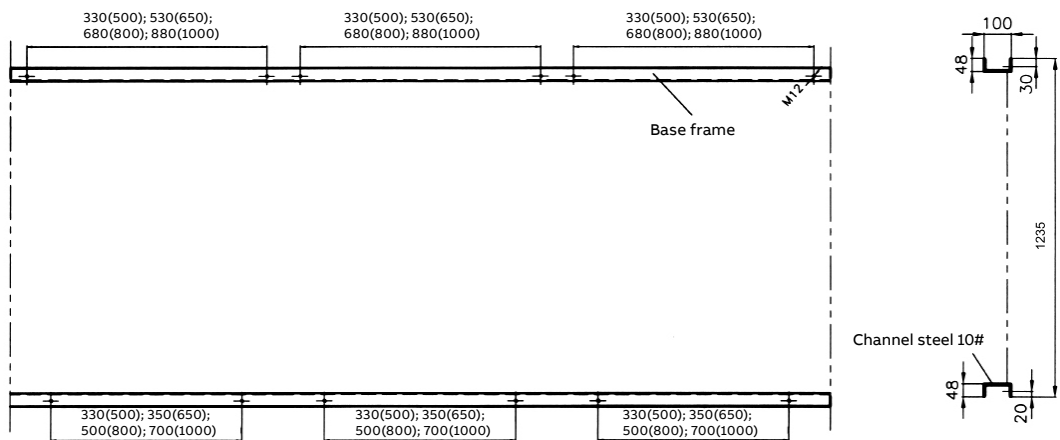

Figure 17.4 Manufacturing diagram of UniGear ZS1 base frame

# UniGear Digital

The SMiS digital platform is a modular platform that integrates various advanced sensor and radio frequency technologies and makes deep integration of IoT and digital technologies according to the application scenarios of MV switchgear. The platform enables real-time comprehensive condition awareness, fault diagnosis and assessment of the health status of MV switchgear, as well as condition monitoring, asset management, sequence control and event logging of key power equipment in substations. The platform provides users with a reliable digital solution for a wide range of applications, meeting their needs today and in the future.

The SMiS digital platform is suitable for the full range of medium voltage switchgear and is used in a wide range of applications such as smart grids, data centers, petrochemicals, infrastructure and rail transit.

#### **Customer benefit**

The SMiS digital platform is suitable for the full range of medium voltage switchgear and is used in a wide range of applications such as smart grids, data centers, petrochemicals, infrastructure and rail transit.

#### **Improving their equipment management capabilities**

The digital real-time monitoring solution combined with the medium voltage switchgear enables intelligent and comprehensive condition awareness of the MV switchgear. Based on the relevant data, the health status of the equipment can be further assessed, potential risks can be identified in advance, and operation and maintenance recommendations can be provided, helping users to improve their overall equipment management capabilities and respond in a timely manner.

#### **Further improving the reliability of the power supply system**

Based on real-time dynamic tracking and diagnosis of data, the traditional passive preventive maintenance approach is upgraded to a proactive predictive maintenance service, helping customers to prevent potential risks from turning into eventual equipment failures and significantly avoiding unplanned outages.

#### **Optimizing operation & maintenance time and costs**

The digital solution provides a wide range of online monitoring and diagnostic functions, with graphics and real-time status displays, reducing the difficulty of operation and maintenance, improving efficiency and reducing lifecycle management costs.

**SMiS platform structure**

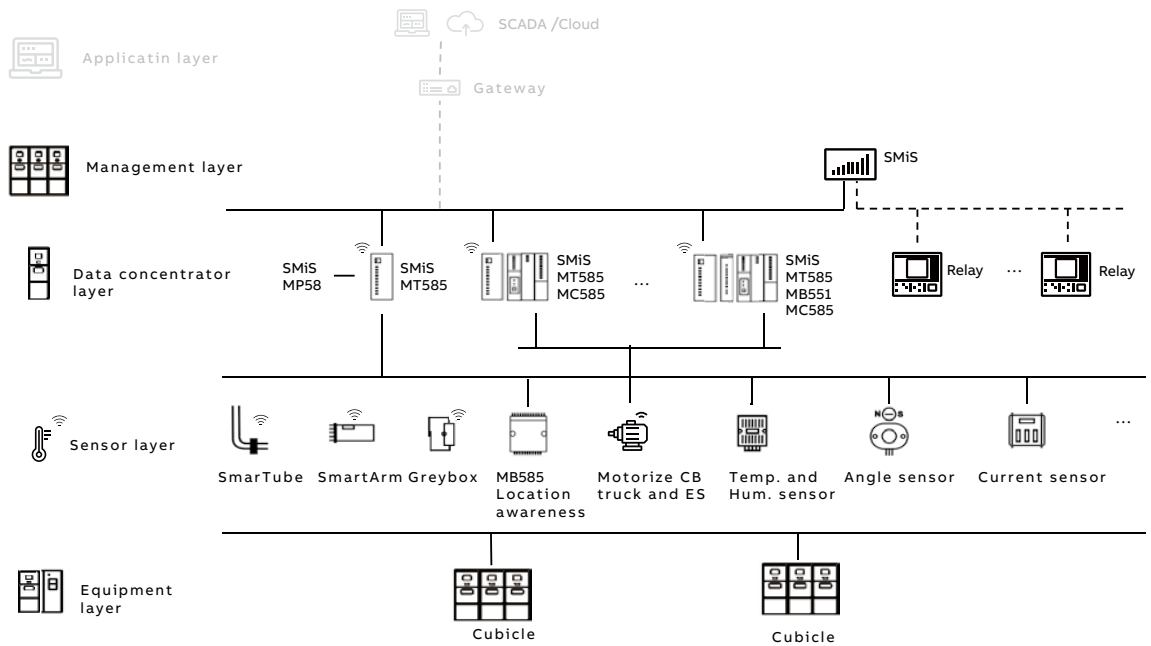

**UniGear Digital**

Based on the SMiS platform, the UniGear Digital solution enables intelligent and comprehensive condition awareness at the equipment level through the interplay of multiple sensor technologies.

The main features includes temperature rise perception, location awareness, environmental perception and motion perception. See more specific information in the digital catalogue.

Configuration	Function
L1: Temperature rise	📶 12 points standard temperature rise monitoring
L2: Standard	L1+ ⚠️ Safe operation assistant system, environmental perception
L3: Feature	L2+ Ⓢ Coil and charging motor monitoring
L4: IoT	L3+ Ⓜ️ Motorize ES and CB truck motion monitoring

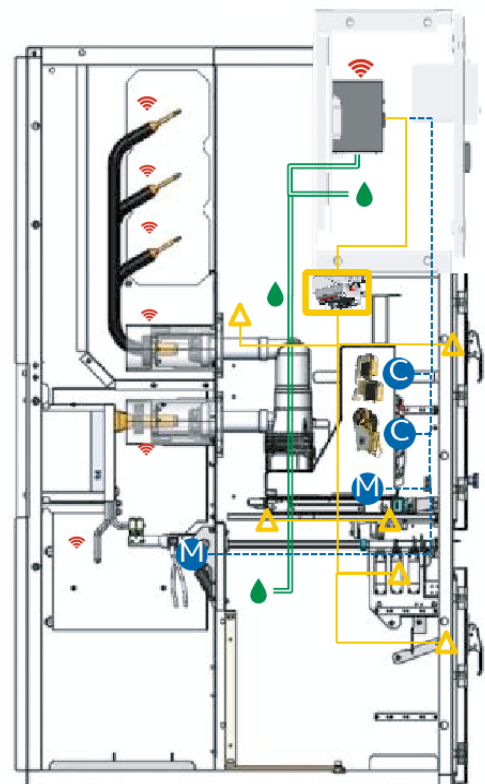

Station level monitoring unit The station level monitoring unit is a station level solution developed by ABB. By collecting and aggregating information and data from the switchgear in the station, the solution provides the user with condition monitoring, asset management, sequence control and event logging of critical power equipment, which effectively improves the efficiency of operation and maintenance and increases the reliability of power consumption.

The station-level monitoring unit is equipped with a 10" high-end industrial all-in-one computer, which supports capacitive multi-touch operation and has excellent human-machine interface. It meets and passes the CE certification.

